



Ingersoll-Rand®

2475
Air Compressor
Parts List

C.C.N : 22400394
REV. : A
DATE : JANUARY 2004



A series of horizontal lines for writing, starting from the top right of the pen icon and extending across the width of the page. The lines are evenly spaced and cover the majority of the page's vertical space.

FIGURE 1. COMPRESSOR FRAME ASSEMBLY.

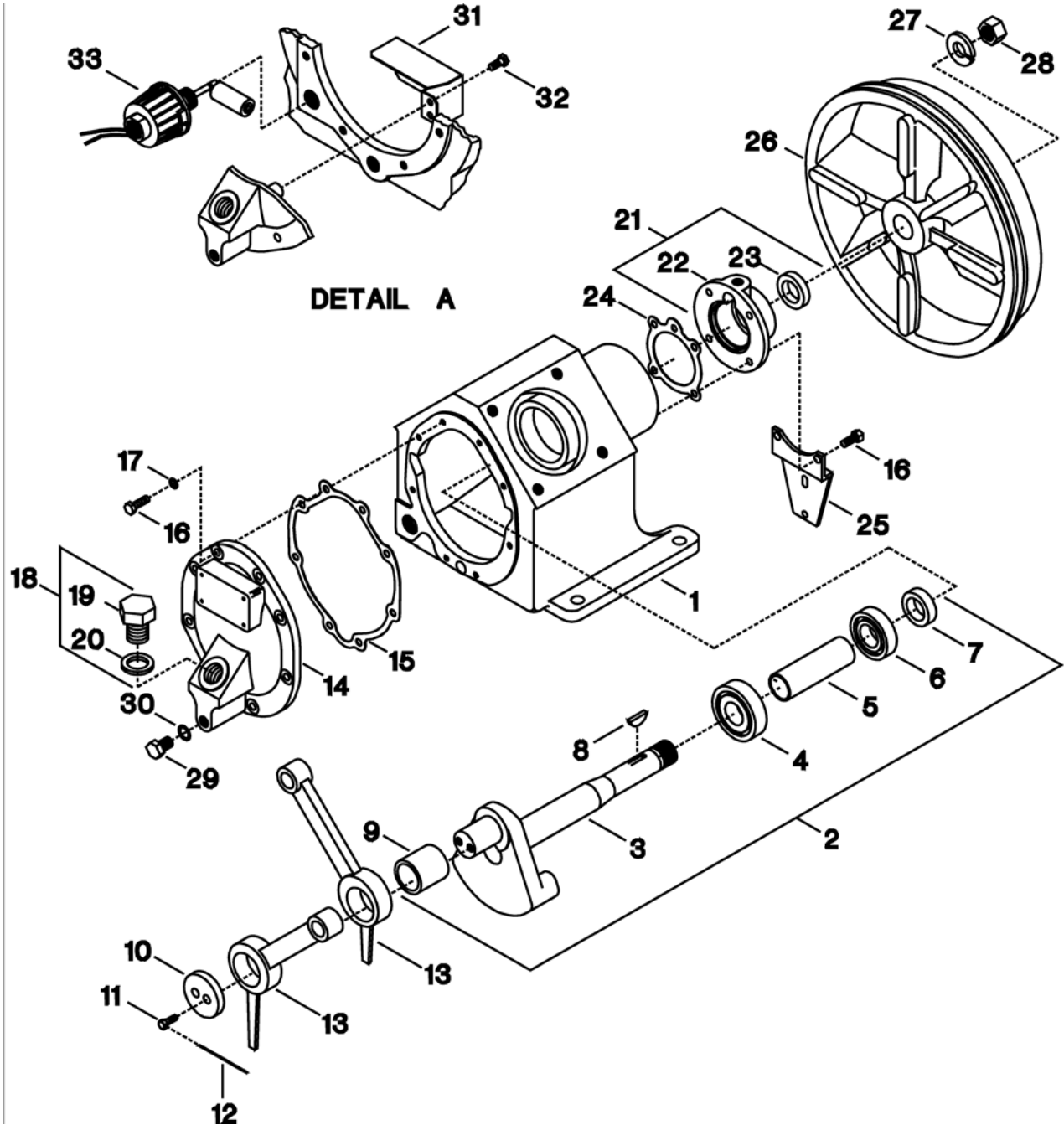

ITEM	CCN	DESCRIPTION	QTY	ITEM	CCN	DESCRIPTION	QTY
1-1	32247728	FRAME, COMPRESSOR	1	1-16	95105250	CAPSCREW, HEX - 5/16-18 X 1"	12
1-2	32496507	ASSEMBLY, CRANKSHAFT COMPLETE	1	1-17	95674651	GASKET, COPPER WASHER - 5/16"	8
1-3	NSS	• CRANKSHAFT	1	1-18	32279549	PLUG, OIL FILLER - COMPLETE	1
1-4	32248122	• BEARING, BALL	1	1-19	NSS	PLUG, OIL FILLER	1
1-5	32006496	• SPACER, CRANKSHAFT BEARING	1	1-20	32247850	O-RING, OIL FILLER PLUG	1
1-6	95134185	• BEARING, BALL WITH SNAP RING	1	1-21	97331060	ASSEMBLY, SHAFT END COVER	1
1-7	37127669	• RING, BEARING RETAINER	1	1-22	NSS	L COVER, SHAFT END	1
1-8	95433173	• KEY, WOODRUFF	1	1-23	32499923	L SEAL	1
1-9	30210199	• BUSHING, CRANKPIN	1	1-24	32247876	GASKET, SHAFT END COVER	1
1-27	95081808	• LOCKWASHER, SPRING - 3/4"	1	1-25	32157349	BRACKET, INTERCOOLER CLAMP	1
1-28	95076816	• NUT, HEX	1	1-26	32496432	BELT WHEEL ELECTRIC MOTOR DRIVE	1
1-10	30210298	CAP, CRANKPIN	1	1-26	32496424	BELT WHEEL GASOLINE ENGINE DRIVE	1
1-11	95101911	CAPSCREW	2	1-29	95053526	CAPSCREW, HEX - 1/2-13 X 3/4"	1
1-12	37605193	LOCKWIRE	1	1-30	95674701	GASKET, COPPER	1
1-13	32004152	ROD, CONNECTING	2	1-31	32295222	BAFFLE, OIL LEVEL SWITCH	1
1-14	32496663	COVER, FRAME END	1	1-32	95053070	CAPSCREW	2
1-15	32247884	GASKET, FRAME END COVER	1	1-33	22102388	KIT, LOW OIL LEVEL SWITCH	1

FIGURE 2. HIGH PRESSURE VALVE PLATE ASSEMBLY.

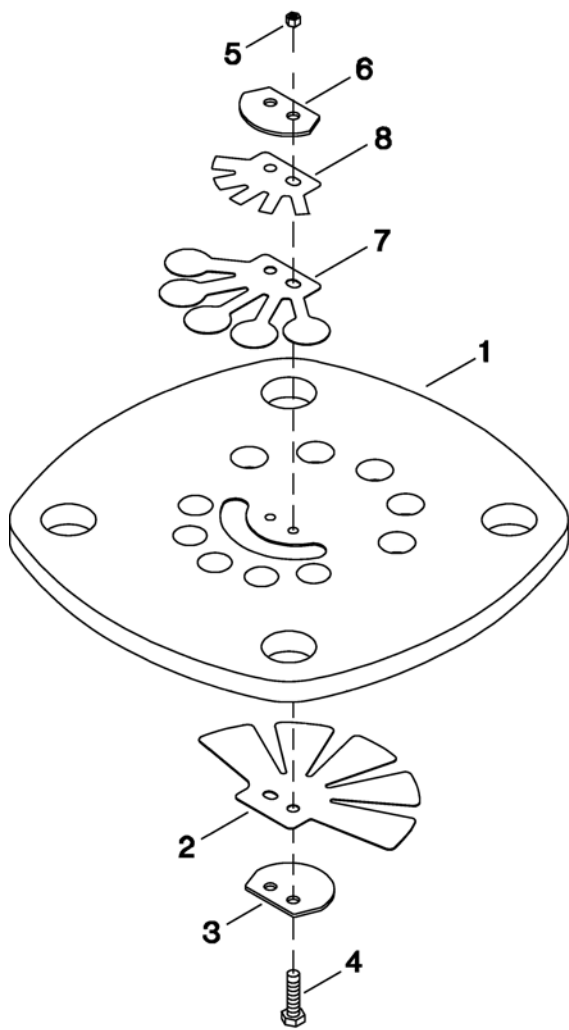
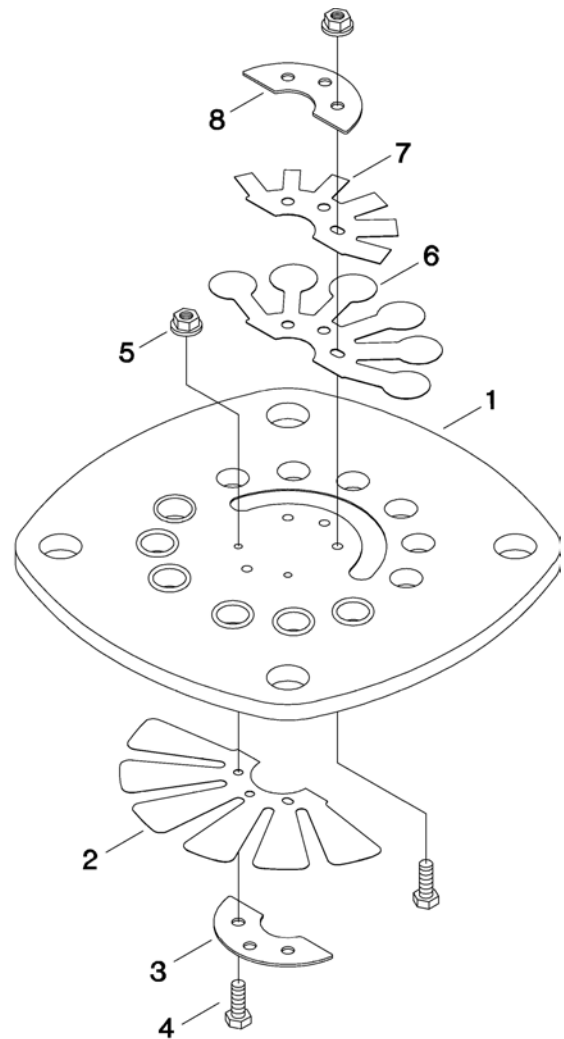

FIGURE 3. LOW PRESSURE VALVE PLATE ASSEMBLY.



ITEM	CCN	DESCRIPTION	QTY
REF.	32310799	ASSEMBLY, VALVE PLATE - HIGH PRESSURE	1
2-1	NSS	PLATE, VALVE - HIGH PRESSURE	1
2-2	32236671	VALVE, FINGER - INLET	1
2-3	32297343	RETAINER, VALVE HP	1
2-4	97511042	SCREW, HEX HEAD - M3 X 16	2
2-5	97511059	NUT, HEX - M3 WITH LOCKWASHER	2
2-6	32295461	RETAINER, FINGER VALVE - DISCHARGE	1
2-7	32241010	VALVE, FINGER - DISCHARGE	1
2-8	32295479	VALVE, DAMPER - DISCHARGE	1

ITEM	CCN	DESCRIPTION	QTY
REF.	32248205	ASSEMBLY, VALVE PLATE	1
3-1	NSS	PLATE, VALVE - LOW PRESSURE	1
3-2	32248130	VALVE, FINGER - INLET	1
3-3	32248148	RETAINER, FINGER VALVE - INLET	1
3-4	32247512	SCREW, HEX HEAD - M4 X 12	6
3-5	32248171	NUT, HEX - M4 WITH LOCKWASHER	6
3-6	32248155	VALVE, FINGER - DISCHARGE	1
3-7	32294464	VALVE, DAMPER - DISCHARGE	1
3-8	32248163	VALVE, RETAINER - DISCHARGE	1

FASTENER TORQUE REQUIREMENTS FOR BARE COMPRESSOR PUMP

Torque values for critical nut, bolt, and capscrew fasteners are listed below.

Gradually and evenly in two stages, tighten each fastener to the final torque using a criss-cross tightening sequence. Use only calibrated torque wrenches.

THREADED FASTENER LOCATION	TORQUE
HIGH PRESSURE HEAD BOLT	75
LOW PRESSURE HEAD BOLT	75
CYLINDER FLANGE	50
FRAME END COVER	17
SHAFT END COVER	17
CRANKPIN CAP	11
HIGH PRESSURE VALVE - IN	11-15 IN LB
LOW PRESSURE VALVE - IN	25-30 IN LB
HIGH PRESSURE VALVE - OUT	11-15 IN LB
LOW PRESSURE VALVE - OUT	25-30 IN LB
BELT WHEEL	60

FIGURE 4. MODEL 2475 BARE COMPRESSOR PUMP.

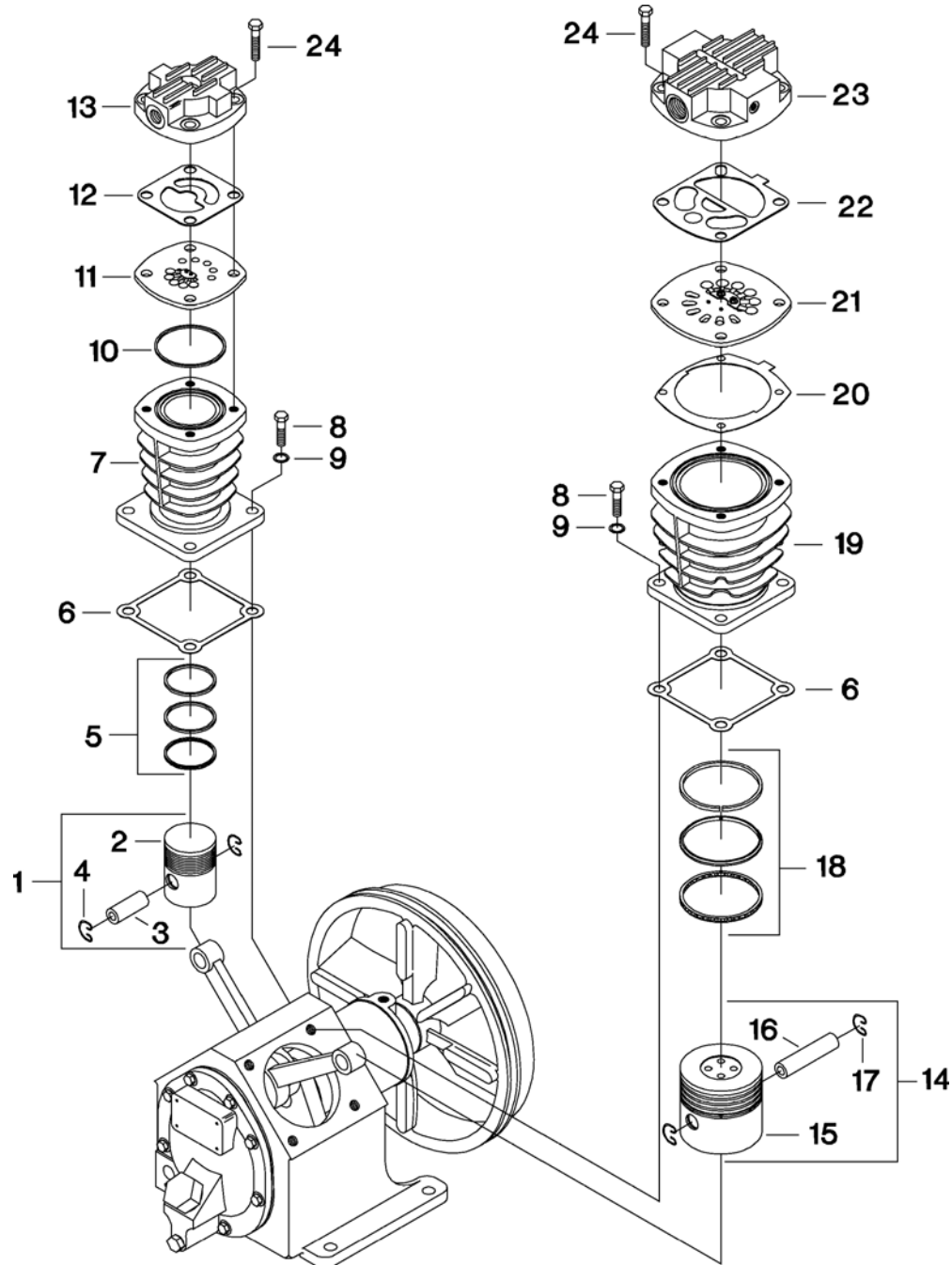

ITEM	CCN	DESCRIPTION	QTY
4-1	32496598	PISTON, AIR - COMPLETE - 2.5" HIGH PRESSURE	1
4-2	NSS	PISTON - AIR - 2.5"	1
4-3	30287783	PIN, PISTON	1
4-4	30298020	RING, LOCK	2
4-5	32307910	SET, PISTON RING - 2.5"	1
4-6	32247868	GASKET, CYLINDER/FLANGE	2
4-7	32247652	CYLINDER - 2.5" - HIGH PRESSURE	1
4-8	95053567	CAPSCREW, HEX - 1/2-13 X 1-1/4"	8
4-9	95674701	GASKET, COPPER - 1/2"	8
4-10	32246878	O-RING, VALVE PLATE - HIGH PRESSURE	1
4-11	32310799	ASSEMBLY, VALVE PLATE - HIGH PRESSURE (SEE FIGURE 2)	1
4-12	32247926	GASKET, AIRHEAD - HIGH PRESSURE	1

ITEM	CCN	DESCRIPTION	QTY
4-13	32247827	AIRHEAD - HIGH PRESSURE	1
4-14	32496564	PISTON, AIR - COMPLETE - 4" - LOW PRESSURE	1
4-15	NSS	PISTON, AIR - 4"	1
4-16	30288393	PIN, PISTON	1
4-17	30298020	RING, LOCK	2
4-18	32307928	SET, PISTON RING - 4"	1
4-19	32293540	CYLINDER, - 4" LOW PRESSURE	1
4-20	32248197	GASKET, VALVE PLATE - LOW PRESSURE	1
4-21	32248205	ASSEMBLY, VALVE PLATE - LOW PRESSURE (SEE FIGURE 3)	1
4-22	32248189	GASKET, AIRHEAD - LOW PRESSURE	1
4-23	32293557	AIRHEAD - LOW PRESSURE	1
4-24	95104188	CAPSCREW, HEX - 1/2-13 X 1-3/4"	8

FIGURE 5. TYPICAL MODEL 2475 INTERCOOLER ASSEMBLY.

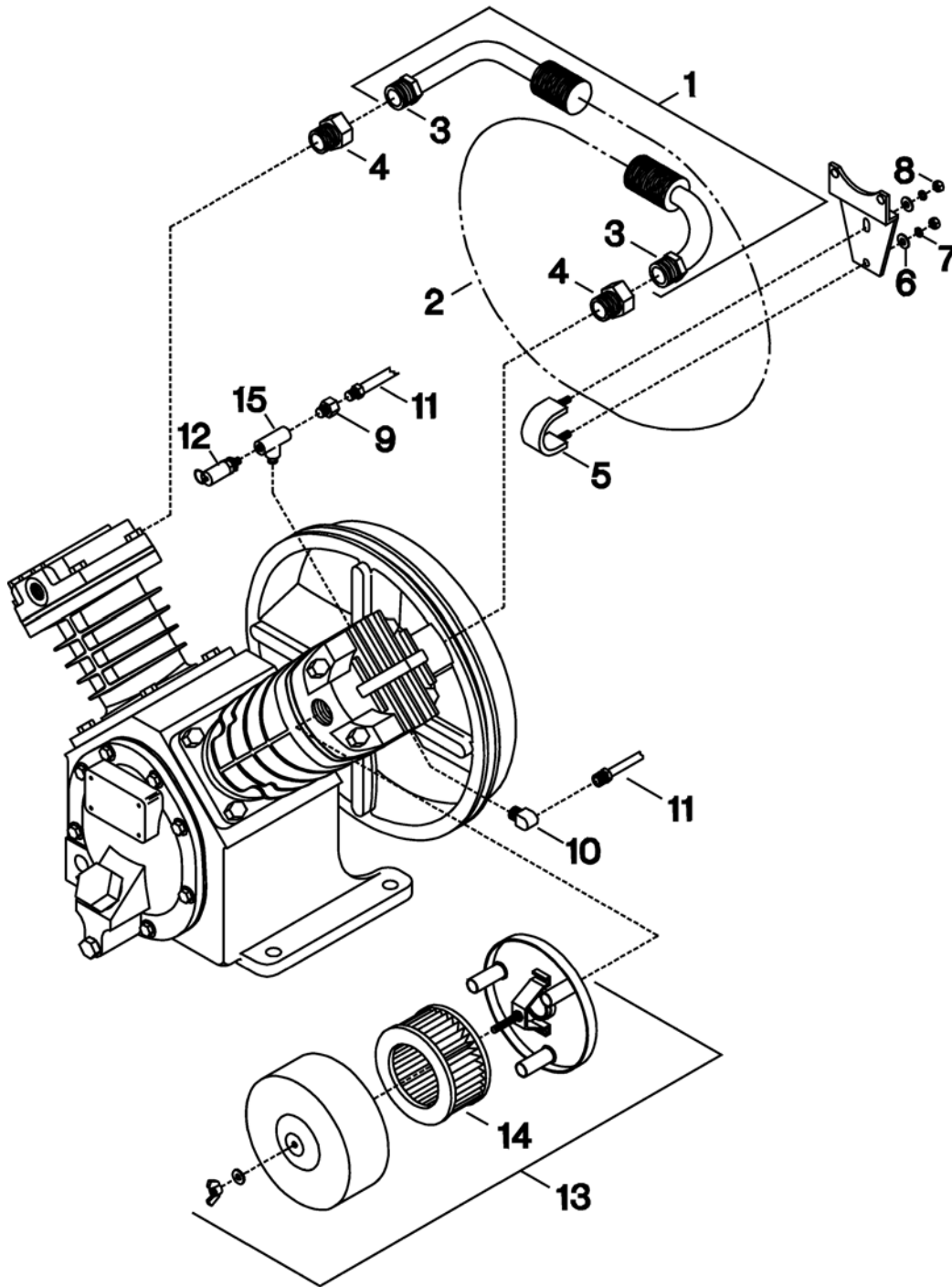

ITEM	CCN	DESCRIPTION	QTY	ITEM	CCN	DESCRIPTION	QTY
5-1	32499196	ASSEMBLY, INTERCOOLER	1	5-11	32247892	ASSEMBLY, TUBE - BREATHER	1
5-2	NSS	• INTERCOOLER	1	5-12	72062185	VALVE, RELIEF - 80 PSIG	1
5-3	95108577	• NUT, TUBE - 3/4"	2	5-13	32170953	FILTER, INLET - COMPLETE - 10 MICRON	1
5-4	95083275	CONNECTOR, TUBE	2	5-14	32170979	ELEMENT, FILTER - 10 MICRON	1
5-5	32247942	CLAMP, INTERCOOLER	1	5-13	37170834	FILTER, INLET - COMPLETE - 4 MICRON	1
5-6	95094298	WASHER, FLAT - 1/4"	2	5-14	32165466	ELEMENT, FILTER - 4 MICRON	1
5-7	95648150	LOCKWASHER, SPRING - 1/4"	2	5-15	37143542	ELBOW, STREET	1
5-8	95416335	NUT, HEX - 1/4-20	2				
5-9	95082483	CONNECTOR, TUBE	1				
5-10	95031860	ELBOW, TUBE	1				

SIMPLEX ELECTRIC MOTOR MODELS

AIR COMPRESSOR PUMP

CCN	DESCRIPTION	QTY
32304370	AIR COMPRESSOR PUMP GROUP	1
95114476	PUMP, BARE COMPRESSOR CAPSCREW, HEX - 1/2-13 X 1-1/2 (TO MOUNT PUMP TO BASE)	4
95458808	NIPPLE, CLOSE 3/4 X 1-3/8	1
95716890	LOCKWASHER, SPRING - 1/2 (FOR PUMP MOUNTING CAPSCREWS)	4

CONTROLS

CCN	DESCRIPTION	QTY
	COMMON	
31385693	VALVE, SAFETY / RELIEF - 200 PSIG	1
32174286	VALVE, SAFETY / RELIEF (DISCHARGE) - 325 PSIG	1
32499816	GAUGE, AIR PRESSURE - 0-300 PSIG, 1/4 NPT, 9 O'CLOCK	1
32179038	PLUG, PIPE - 1/4	1
	CENTER DISCHARGE UNITS	
56288772	SWITCH, PRESSURE - SIEMENS W / UNLOADER VALVE & LEVER	1
32333072	ASSEMBLY, TUBE - PRESSURE SWITCH TO CHECK VALVE	1
32499626	ASSEMBLY, DISCHARGE TUBE	1
85582229	VALVE, CHECK - 5/8 T X 3/4 NPT	1
32145088	ELBOW, TUBE - 3/4 X 3/4 WITH PORT	1
95031795	TUBE ELBOW - 5/8 X 1/2	1
95426714	NIPPLE, CLOSE - 1/4 X 7/8	1
	FULLY PACKAGED UNITS	
56288764	SWITCH, PRESSURE - SIEMENS W / UNLOADER VALVE (FULLY PACKAGED UNITS)	1
32221228	TEE, MALE BRANCH -1/4	1
32322281	ASSEMBLY, TUBE - PRESSURE SWITCH TO CHECK VALVE 2475N NEMA 1 IFCV	1
32322299	ASSEMBLY, TUBE - PRESSURE SWITCH TO CHECK VALVE 2475D NEMA 1 IFCV	1
32323172	ASSEMBLY, TUBE - UNL 2475N7.5 PRESS SW TO CK VLV W/ROT SWITC	11
32323396	ASSEMBLY, TUBE - MM/CK VLV/ACA C 2475N (INV CK VLV)	1
32323404	ASSEMBLY, TUBE - N4 PS/CK VLV 2475D (INV CK VLV)	1
32323412	ASSEMBLY, TUBE - MM/CK VLV/TEB G 2475N	1
32333098	ASSEMBLY, TUBE - PRESSURE SWITCH TO CHECK VALVE 2475N (SIEMENS)	1
32333106	ASSEMBLY, TUBE - PRESSURE SWITCH TO CHECK VALVE 2475D (SIEMENS)	1
32333114	ASSEMBLY, TUBE - PRESSURE SWITCH TO CHECK VALVE 2475N7.5 (SIEMENS)	1
32334849	ASSEMBLY, TUBE - PRESSURE SWITCH TO CHECK VALVE 2475N5	1
32334872	ASSEMBLY, TUBE - PRESSURE SWITCH TO CHECK VALVE 2475N7.5	1
32334880	ASSEMBLY, TUBE - PRESSURE SWITCH TO CHECK VALVE 2475D5	1
32209157	NIPPLE, LONG - 1/4 X 5	1
95082467	CONNECTOR, MALE - 1/4 X 1/4	1

AIR RECEIVER TANK

CCN	DESCRIPTION	QTY
97336259	TANK, AIR RECEIVER - 80 GALLON VERTICAL (CENTER DISCHARGE UNITS)	1
32496499	TANK, AIR RECEIVER - 80 GALLON VERTICAL (FULLY PACKAGED UNITS)	1
32498768	TANK, AIR RECEIVER - 80 GALLON HORIZONTAL (175 PSIG UNITS)	1
32251837	TANK, AIR RECEIVER - 80 GALLON HORIZONTAL (250 PSIG UNITS)	1
32223596	VALVE, BALL - 3/4 (CENTER DISCHARGE UNITS)	1
32106569	VALVE, BALL - 3/4 (FULLY PACKAGED UNITS)	1
32027120	VALVE, MANUAL DRAIN (CENTER DISCHARGE UNITS)	1

BASEPLATE

CCN	DESCRIPTION	QTY
32195224	BASEPLATE PACKAGE GROUP	1
32333445	ASSEMBLY, SUBBASE	1
32048993	ASSEMBLY, PRESSURE SWITCH TUBE CLAMP	2

STARTERS

CCN	DESCRIPTION	QTY
	CENTER DISCHARGE UNITS	
56272305	STARTER, 5HP - 200-1-60	1
56272040	STARTER, 5HP - 230-1-60	1
56272057	STARTER, 5HP - 200-3-60	1
56272222	STARTER, 5HP - 230-3-60	1
56272230	STARTER, 5HP - 460-3-60	1
56272164	STARTER, 5HP - 575-3-60	1
56272297	STARTER, 7.5HP - 230-1-60	1
56272198	STARTER, 7.5HP - 200-3-60	1
56272131	STARTER, 7.5HP - 230-3-60	1
56272149	STARTER, 7.5HP - 460-3-60	1
56272214	STARTER, 7.5HP - 575-3-60	1
97330229	PLATE, STARTER MOUNT FULLY PACKAGED UNITS	1
56272305	STARTER, 5HP - 200-1-60	1
56272040	STARTER, 5HP - 230-1-60	1
56272057	STARTER, 5HP - 200-3-60	1
81292468	STARTER, 5HP - 230/460-3-60	1
56272222	STARTER, 5HP - 230-3-60	1
56272164	STARTER, 5HP - 575-3-60	1
81292450	STARTER, 7.5HP - 230/460-3-60	1
56272297	STARTER, 7.5HP - 230-1-60	1
56272198	STARTER, 7.5HP - 200-3-60	1
56277214	STARTER, 7.5HP - 575-3-60	1

ELECTRIC DRAIN

CCN	DESCRIPTION	QTY
	COMMON	
54393335	ELBOW, STREET - 1/2	1
54579248	DRAIN, EDV ELECTRIC	1
95989638	CONNECTOR, SWIVEL - FEMALE VERTICAL TANK UNITS	1
32237851	NIPPLE, LONG - 1/2 X 4-1/2	1
54386974	COUPLING, BRASS - 1/2	1
95242517	NIPPLE, LONG - 1/2 X 6	1

DRIVE

CCN	DESCRIPTION	QTY
	MOTORS - CENTER DISCHARGE UNITS	
32288631	MOTOR, 5HP - 230-1-60	1
97331656	MOTOR, 5HP - 230/460-3-60	1
97331649	MOTOR, 5HP - 200-3-60	1
97331664	MOTOR, 5HP - 575-3-60	1
32065526	MOTOR, 5HP - 200-1-60	1
97331656	MOTOR, 5HP - 230-3-60	1
32309437	MOTOR, 7.5HP - 230-1-60	1
97331680	MOTOR, 7.5HP - 230/460-3-60	1
97331672	MOTOR, 7.5HP - 200-3-60	1
	BELTS	
95099479	BELT, V - A62 (5HP CENTER DISCHARGE UNITS)	1
95099511	BELT, V - A70 (5HP FULLY PACKAGED UNITS)	1
95099461	BELT, V - A60 (7.5HP CENTER DISCHARGE UNITS)	1
	MOTORS - FULLY PACKAGED UNITS	
32065526	MOTOR, 5HP - 200-1-60	1
32288631	MOTOR, 5HP - 230-1-60	1
32036790	MOTOR, 5HP - 200-3-60	1
32036857	MOTOR, 5HP - 230/460-3-60	1
32036865	MOTOR, 5HP - 575-3-60	1
	SHEAVE SETS	
32281768	SET, SHEAVE (5HP)	1
54507975	SET, SHEAVE (7.5HP, 230-1-60)	1
54507967	SET, SHEAVE (7.5HP, ALL EXCEPT 230-1-60)	1
	COMMON	
32175556	CAPSCREW, SERRATED WASHER HEAD - 3/8-16 X 1 (MOTOR MOUNTING)	4
54370523	NUT, CONICAL KEPS - 3/8 (MOTOR MOUNTING)	VAR

AIR COOLED AFTERCOOLER (ACAC)

CCN	DESCRIPTION	QTY
32174286	VALVE,SAFETY(DISCH)325PS SA25-0A325	1
32188450	TUBE ASSY,COMPR/ACAC 242 2420/2475	1
32322265	TUBE ASSY, ACAC/RECVR 2475N IFCV	1
32322273	TUBE ASSY, ACAC/RECVR 2475D IFCV	1
95031795	TUBE ELBOW 5/8X1/2 75A10B20	1
32498149	249IFHD10-8	1
85582229	COIL, AFTERCOOLER MODINE 2475 5HP	1
	VALVE, CHECK 3/4" X 5/8T W/ 1/4" & 1/4T PORTS	1

BELTGUARD

CCN	DESCRIPTION	QTY
	WIRE STYLE (CENTER DISCHARGE UNITS)	
32499162	BACK, BELTGUARD - WIRE	1
32499170	FRONT, BELTGUARD - WIRE	1
32496093	CLIP, PVC COATED	4
95916078	WASHER, FLAT - 1/4 ZINC	3
97173595	CAPSCREW, SELF-TAP - 1/4-20 X 1/2	3
97330013	BRACE, WIRE BELTGUARD	1
	SHEET METAL STYLE (FULLY PACKAGED UNITS)	
32281040	BACK, BELTGUARD - SHEET METAL	1
32281057	BRACE, SHEET METAL BELTGUARD (ATTACH TO LOW PRESSURE HEAD)	1
32281065	BRACE, SHEET METAL BELTGUARD (ATTACH TO HIGH PRESSURE HEAD)	1
32281073	COVER, AIR COOLED AFTERCOOLER	1
32000705	SCREW, SELF-TAPPING - 3/8-16 X 3/4	4
32187056	SCREW, SELF-DRILL - 1/4-14	14

DUPLEX ELECTRIC MOTOR MODELS

AIR COMPRESSOR PUMP

CCN	DESCRIPTION	QTY
32304370	PUMP, BARE COMPRESSOR	2
95114476	CAPSCREW, HEX - 1/2-13 X 1-1/2 (TO MOUNT PUMP TO BASE)	8
95716890	LOCKWASHER, SPRING - 1/2 (FOR PUMP MOUNTING CAPSCREWS)	8

CONTROLS

CCN	DESCRIPTION	QTY
56288764	SWITCH, PRESSURE - WITH UNLOADER VALVE	1
56288798	SWITCH, PRESSURE	1
95426714	NIPPLE, CLOSE	1
32013872	GAUGE, PRESSURE	1
32179038	PLUG, PIPE	4
32301483	ASSEMBLY, SHUTTLE VALVE	1
32333528	ASSEMBLY, TUBE - IC/IC 2-2475D TANK (LEAD/LAG)	1
32333015	ASSEMBLY, TUBE - PL.UNL SH VLV/DUP SIEMENS 2-2475D	1

BASE PACKAGE

CCN	DESCRIPTION	QTY
32251894	TANK, AIR RECEIVER - 2-2475D	1
32251902	TANK, AIR RECEIVER - 2-2475E	1
32223596	ASSEMBLY, BALL VALVE - 3/4" (2-2475D)	1
32223604	ASSEMBLY, BALL VALVE - 1" (2-2475E)	1
32116295	ASSEMBLY, TUBE - REC / MTD BLOCK RIGHT HAND (2-2475E7.5)	1
32116303	ASSEMBLY, TUBE - REC / MTD BLOCK LEFT HAND (2-2475E7.5)	1
32118382	ASSEMBLY, TUBE - REC / MTD BLOCK RIGHT HAND (2-2475D5)	1
32118390	ASSEMBLY, TUBE - REC / MTD BLOCK LEFT HAND (2-2475D5)	1
32333551	ASSEMBLY, TUBE - REC / MTD BLOCK RIGHT HAND (2-2475E5)	1
32333544	ASSEMBLY, TUBE - REC / MTD BLOCK LEFT HAND (2-2475E5)	1
31385693	VALVE, SAFETY/ RELIEF - 200 PSIG	1
32157554	CONNECTOR, MALE - 5/16 X 1/4	2
32179038	PLUG, PIPE - 1/4 (2-2475E)	1
32236333	ASSEMBLY, TUBE - SHUTTLE VALVE / I/C TEE (2-2475E)	1
95007522	TEE, MALE TUBE - 5/16 X 1/8	1
95037453	BUSHING, REDUCER - 3/4 X 1/4	1
95037826	BUSHING, REDUCING - 1-1/2 X 1	1

MOTORS

CCN	DESCRIPTION	QTY
32036931	MOTOR, 7.5 HP - 200-3-60	2
32036972	MOTOR, 7.5 HP - 230/460-3-60	2
32036980	MOTOR, 7.5 HP - 575-3-60	2
32175556	CAPSCREW, 3/8-16 X 1	8
37177052	CLAMP, MOTOR	2
37177656	BOLT, BELT TIGHTENER	2
37179207	CLIP, BELT TIGHTENER	2
54370523	NUT, CONICAL KEPS - 3/8	4
56271406	SET, SHEAVE	2
95677324	BELT, V - A74	2

ALTERNATORS

CCN	DESCRIPTION	QTY
56272917	ALTERNATOR, 7.5 HP - 200-3-60	1
56272966	ALTERNATOR, 7.5 HP - 230-3-60	1
56273030	ALTERNATOR, 7.5 HP - 460-3-60	1
56273063	ALTERNATOR, 7.5 HP - 575-3-60	1
95074266	SCREW, TAPPING - 1/4-20 X 1/2	3
32298705	BRACKET, ALTERNATOR	1
32000705	SCREW, SELF-TAPPING - 3/8-16 X 3/4	4
VAR.	HEATER	6

AIR COOLED AFTERCOOLER

CCN	DESCRIPTION	QTY
95037826	BUSHING, REDUCING - 1-1/2 X 1	1

CCN	DESCRIPTION	QTY
95006565	TEE, PIPE - 1"	1
95640074	NIPPLE, CLOSE 1 X 1-1/2	1
32186421	BUSHING, REDUCING - 1 X 3/4	2
85582112	VALVE, CHECK - 3/4 X 3/4	2
32174286	VALVE, SAFETY / RELIEF - DISCHARGE (325 PSIG)	2
32324295	ASSEMBLY, TUBE - ACAC / TANK	2
32324287	ASSEMBLY, TUBE - PUMP / ACAC	2
32498065	COIL, AFTERCOOLER - 7.5HP	2

BELTGUARD

CCN	DESCRIPTION	QTY
32281040	BACK, BELTGUARD - SHEET METAL	2
32281057	BRACE, SHEET METAL BELTGUARD (ATTACH TO LOW PRESSURE HEAD)	2
32281065	BRACE, SHEET METAL BELTGUARD (ATTACH TO HIGH PRESSURE HEAD)	2
32281073	COVER, AIR COOLED AFTERCOOLER	2
32000705	SCREW, SELF-TAPPING - 3/8-16 X 3/4	8
32187056	SCREW, SELF-DRILL - 1/4-14	28

PNEUMATIC DRAIN VALVE

CCN	DESCRIPTION	QTY
32311102	ASSEMBLY, PNEUMATIC DRAIN VALVE	1
32496325	TEE, MALE RUN	1
32335457	ASSEMBLY, TUBE - DRAIN VALVE TO COMPRESSOR	1
32311128	ASSEMBLY, TUBE - CONDENSATE	1
95110441	ELBOW, TUBE - 5/16 X 1/4	1

GASOLINE ENGINE MODELS

CCN	DESCRIPTION	QTY	CCN	DESCRIPTION	QTY
32343733	TUBING GROUP ASSEMBLY, DISCHARGE TUBE - KOHLER BASEPLATE MOUNTED UNITS	1	32497919	BRACE, BELTGUARD - LP- KAWASAKI UNITS	1
32343709	ASSEMBLY, DISCHARGE TUBE - KOHLER TANK MOUNTED UNITS	1	32308686	BRACE, BELTGUARD - HONDA UNITS	1
32343741	ASSEMBLY, DISCHARGE TUBE - KAWASAKI BASEPLATE MOUNTED UNITS	1	32281065	BRACE, BELTGUARD - HP - KOHLER UNITS	1
32343717	ASSEMBLY, DISCHARGE TUBE - KAWASAKI TANK MOUNTED UNITS	1	32497414	BRACE, BELTGUARD - HP - KAWASAKI UNITS	1
32343758	ASSEMBLY, DISCHARGE TUBE - HONDA BASEPLATE MOUNTED UNITS	1	32000705	SCREW, SELF-TAPPING - 3/8-16 X 3/4	VAR
32343725	ASSEMBLY, DISCHARGE TUBE - HONDA TANK MOUNTED UNITS	1	32187056	SCREW, SELF-DRILLING - 1/4-14	VAR
54398508	CONTROLS GROUP CONTROL, THROTTLE SLOWDOWN - KOHLER BASEPLATE MOUNTED UNITS	1	95916094	WASHER, FLAT - 3/8 - KAWASAKI UNITS	2
54398144	CONTROL, THROTTLE SLOWDOWN - KOHLER TANK MOUNTED UNITS	1		ENGINE & DRIVE GROUP	
54398169	CONTROL, THROTTLE SLOWDOWN - KAWASAKI UNITS	1	97337901	ENGINE, KOHLER - NO ALTERNATOR	1
54398151	CONTROL, THROTTLE SLOWDOWN - HONDA UNITS	1	97337919	ENGINE, KOHLER - WITH ALTERNATOR	1
49816283	VALVE, AUXILIARY	1	32497331	ENGINE, KAWASAKI - NO ALTERNATOR	1
32174286	* VALVE, SAFETY / RELIEF - 325 PSIG DISCHARGE	1	32497349	ENGINE, KAWASAKI - WITH ALTERNATOR	1
31385693	* VALVE, SAFETY / RELIEF - 200 PSIG RECEIVER	1	81297467	ENGINE, HONDA	1
37155751	* MUFFLER, DISCHARGE UNLOADER	1	32295891	BELT, DRIVE - KOHLER UNITS	1
32013898	GAUGE, PRESSURE - BASEPLATE MOUNTED UNITS	1	32497869	BELT, DRIVE - KAWASAKI UNITS	1
81296253	GAUGE, PRESSURE - TANK MOUNTED UNITS	1	32310153	BELT, DRIVE - HONDA UNITS	1
95031795	TUBE ELBOW 5/8X1/2 (ALL)	1	56276207	SHEAVE, KOHLER ENGINE	1
95481982	NIPPLE, PIPE - 1/2" X 3" (KAWASAKI TANK MOUNTED)	1	32497554	SHEAVE, KAWASAKI ENGINE	1
32262545	NIPPLE, PIPE - 1/2" X 4" (KOHLER / HONDA TANK MOUNTED)	1	81297475	SHEAVE, HONDA ENGINE	1
	AIR RECEIVER TANK GROUP		32497935	CLAMP, ENGINE - KAWASAKI UNITS	1
32175507	TANK, AIR RECEIVER - BASEPLATE MOUNTED UNITS	1	32497877	TENSIONER, BELT - KAWASAKI UNITS (INCL CLAMP, MOUNTING CAPSCREWS, TENSIONING BOLT & CLIP)	1
32496697	TANK, AIR RECEIVER - KOHLER / HONDA TANK MOUNTED UNITS	1	32145898	TENSIONER, BELT - KOHLER & HONDA UNITS	1
32497372	TANK, AIR RECEIVER - KAWASAKI TANK MOUNTED UNITS	1	30219802	CLIP, BELT TIGHTENER - KOHLER & HONDA UNITS	1
32223588	VALVE, SERVICE	1	32308140	BRACE, ENGINE / COMPRESSOR - HONDA UNITS	1
32027120	VALVE, MANUAL DRAIN	1	32246621	BRACE, ENGINE / COMPRESSOR - KOHLER UNITS	1
32309346	KIT, VIBRATION MOUNT - HONDA TANK MOUNTED UNITS	1	95203444	KEY, KOHLER & HONDA UNITS	1
32209165	BRACKET, TANK MOUNTING - BASEPLATE MOUNTED UNITS	2		MISCELLANEOUS HARDWARE & FITTINGS	
32034134	BOLT, U - BASEPLATE MOUNTED UNITS	2	95417507	NIPPLE, CLOSE - 1/2 X 1-1/8 - KAWASAKI BASEPLATE MOUNTED UNITS	1
32140576	BASEPLATE UNIT GROUP SUBBASE, KOHLER BASEPLATE MOUNTED UNITS	1	32224909	ELBOW, STREET - 1/8 X 1/8 - KAWASAKI BASEPLATE MOUNTED UNITS	1
32309221	SUBBASE, HONDA BASEPLATE MOUNTED UNITS	1	32499139	CAPSCREW, 5/16-18 X 1-3/4 - KAWASAKI UNITS	2
32497356	SUBBASE, KAWASAKI BASEPLATE MOUNTED UNITS	1	39128558	NUT, WHIZ-LOCK - 5/16-18 - KAWASAKI UNITS	4
95944633	BUSHING, 3/4 X 1/4 (BASEPLATE MOUNTED UNITS)	2	32175556	CAPSCREW, 3/8-16 X 1 - HONDA UNITS	1
32178998	BUSHING, REDUCING - 3/4 X 1/2 (BASEPLATE MOUNTED UNITS)	1	95077053	CAPSCREW, 3/8-16 X 1-1/2 - KOHLER & HONDA UNITS	3
95043766	CAPSCREW, HEX - 3/8-16 X 1-1/2 (BASEPLATE MOUNTED UNITS)	4	95104014	CAPSCREW, 7/16-14X1-1/4 - KOHLER BASEPLATE MOUNTED UNITS	1
95675526	LOCKWASHER, 5/16 (BASEPLATE MOUNTED UNITS)	4	95916854	CAPSCREW, HEX - 7/16 X 1-1/4 - KOHLER TANK MOUNTED UNITS	1
39128558	NUT, WHIZ-LOCK - 5/16-18 (BASEPLATE MOUNTED UNITS)	4	39128566	NUT, WHIZ-LOCK - 3/8-16 (KOHLER / HONDA)	4
	BELTGUARD GROUP		95423695	NUT, HEX - 1/2 - KOHLER & HONDA UNITS	1
56278906	BACK, BELTGUARD - KOHLER UNITS	1	95916094	WASHER, FLAT - 3/8 - KAWASAKI UNITS	VAR
32497398	BACK, BELTGUARD - KAWASAKI UNITS	1	32130387	WASHER, FLAT - 7/16 (2475X12.5G)	1
32308124	BACK, BELTGUARD - HONDA UNITS	1	95751582	LOCKWASHER, 7/16 - KOHLER UNITS	1
56278922	FRONT, BELTGUARD - KOHLER UNITS	1		COMPRESSOR PUMP GROUP	
32497406	FRONT, BELTGUARD - KAWASAKI UNITS	1	32313322	PUMP, BARE COMPRESSOR (INCL STD FILTER & INTERCOOLER SAFETY / RELIEF VALVE)	1
32308116	FRONT, BELTGUARD - HONDA UNITS	1	95114476	CAPSCREW, HEX - 1/2-13 X 1-1/2	4
32281057	BRACE, BELTGUARD - LP - KOHLER UNITS	1	95716890	LOCKWASHER, SPRING - 1/2	4

SERVICE AND ACCESSORY PARTS AND KITS

SERVICE

START-UP KITS

Each Start-Up Kit contains the necessary quantities of All-Season Select Lubricant and standard air filter element(s) to start-up and maintain your compressor for the first year. Start-Up Kits for engine driven models include a replacement engine air filter, engine oil filter and engine oil. See the engine manufacturer's instructions for more detailed engine care information.

CCN	DESCRIPTION	MODELS
32305880	KIT, START-UP	ELECTRIC MOTOR MODELS
32312936	KIT, START-UP	HONDA ENGINE MODELS
32305872	KIT, START-UP	KOHLER ENGINE MODELS
32498511	KIT, START-UP	KAWASAKI ENGINE MODELS

MAINTENANCE PAKS

Maintenance paks contain all the parts necessary for one complete routine maintenance of your compressor. All-Season Select Lubricant, air filter elements and gaskets are included.

CCN	DESCRIPTION
38485330	PAK, MAINTENANCE

STEP SAVER KITS

Step Saver Kits provide all the parts required to perform common repair or scheduled maintenance tasks, such as piston ring replacement or valve replacement.

CCN	DESCRIPTION
32301426	KIT, VALVE
32301517	KIT, RING
32301509	KIT, BEARING & ROD*
32301434	KIT, GASKET

* To repair grooved crankshaft journals, order Shaft Repair Kit 32499949 along with the Bearing & Rod Kit.

OVERHAUL KITS

CCN	DESCRIPTION
32319469	KIT, OVERHAUL

RECOMMENDED SPARES

ITEM	CCN	DESCRIPTION	QTY
1-15	32247884	GASKET, FRAME END COVER	1
1-20	32247850	O-RING, OIL FILLER PLUG	1
1-23	32499923	L SEAL	1
1-24	32247876	GASKET, SHAFT END COVER	1
REF.	32310799	ASSEMBLY, VALVE PLATE - HIGH PRESSURE	1
REF.	32248205	ASSEMBLY, VALVE PLATE	1
4-1	32496598	PISTON, AIR - COMPLETE - 2.5" HIGH PRESSURE	1
4-5	32307910	SET, PISTON RING - 2.5"	1
4-6	32247868	GASKET, CYLINDER/FLANGE	2
4-10	32246878	O-RING, VALVE PLATE - HIGH PRESSURE	1
4-12	32247926	GASKET, AIRHEAD - HIGH PRESSURE	1
4-14	32496564	PISTON, AIR - COMPLETE - 4" - LOW PRESSURE	1
4-18	32307928	SET, PISTON RING - 4"	1
4-20	32248197	GASKET, VALVE PLATE - LOW PRESSURE	1
4-22	32248189	GASKET, AIRHEAD - LOW PRESSURE	1

GASOLINE ENGINE PARTS

CCN	DESCRIPTION	MODELS
32305674	FILTER, OIL	KOHLER ENGINE MODELS
32305682	FILTER, AIR	KOHLER ENGINE MODELS
32305690	PRE FILTER	KOHLER ENGINE MODELS
38487039	KIT, MUFFLER	KOHLER ENGINE MODELS
32498545	FILTER, OIL	KAWASAKI
32498537	FILTER, AIR	KAWASAKI
32498529	PRE FILTER	KAWASAKI

COMPRESSOR LUBRICANT

All Season T30 Select is a synthetic fluid specifically formulated to protect and preserve your Ingersoll-Rand small reciprocating air compressor through a broad range of temperature as well as better start-up in colder climate conditions. With its outstanding formulation, All Season T30 Select enables you to run 2000 hours of service between changeouts under normal operating conditions.

PART NO.	DESCRIPTION
32318875	LUBRICANT, ALL SEASON SELECT - QUART
32318883	LUBRICANT, ALL SEASON SELECT - CASE OF 12 QUARTS

ACCESSORIES

INSTALLATION KITS

Each Installation Kit combines vibration pads and flexible hose into one kit. The kit consists of (4) 5 X 5 vibration pads and (1) ¾ X 13 flexible hose.

CCN	DESCRIPTION
38002242	KIT, INSTALLATION

SILENCERS

Silencers provide excellent noise reduction (2 DBA or 35% reduction in operating noise level) with no pressure drop.

CCN	DESCRIPTION
32323552	SILENCER

VIBRATION PADS

Vibration pads are designed to absorb 40-60% of the sound and vibration of your compressor.

CCN	DESCRIPTION
32320681	PAD, VIBRATION — 4 X 4 STEEL PLATE
32320699	PAD, VIBRATION — 5 X 5 STEEL PLATE
32321002	PAD, VIBRATION — 4 X 4 CORK
32321028	PAD, VIBRATION — 5 X 5 CORK
32321010	PAD, VIBRATION — 6 X 6 CORK

FLEX HOSES

Flex Hoses give flexibility to compressed air piping systems. They provide thermal growth absorption, misalignment compensation, vibration isolation, reduced stress forces on compressor housings and noise reduction.

CCN	DESCRIPTION
32323586	HOSE, FLEX — ½ X 11
38335295	HOSE, FLEX — ½ X 36
38338778	HOSE, FLEX — ½ X 72
32323594	HOSE, FLEX — ¾ X 13
38323309	HOSE, FLEX — ¾ X 24
38335303	HOSE, FLEX — ¾ X 36
38338638	HOSE, FLEX — ¾ X 72
32323602	HOSE, FLEX — 1 X 14
38334033	HOSE, FLEX — 1 X 24
38335311	HOSE, FLEX — 1 X 36
38338646	HOSE, FLEX — 1 X 72
32323610	HOSE, FLEX — 1-½ X 18
38323317	HOSE, FLEX — 1-½ X 20-½
38323325	HOSE, FLEX — 1-½ X 24

Y-STRAINERS

Y-Strainers are designed to prevent foreign particles and sludge from moving downstream.

CCN	DESCRIPTION
32323628	Y-STRAINER, 1/4
32323636	Y-STRAINER, 1/2

INTERCOOLER SEPARATOR KITS

Intercooler Separator Kits remove condensate between the first and second stages.

CCN	DESCRIPTION
32337826	KIT, INTERCOOLER SEPARATOR

EXTERNAL CRANKCASE HEATER KITS

External crankcase heaters are recommended when ambient temperatures are consistently below 32°F (0°C). An easy-to-install external crankcase heater kit is intended for aftermarket use. Two kits may be required for some applications.

CCN	DESCRIPTION
97330385	KIT, EXTERNAL CRANKCASE HEATER

CONSTANT SPEED CONVERSION KITS

Extend the life of your compressor in hot and humid operating conditions by installing Constant Speed Control.

CCN	DESCRIPTION	MODELS
81294621	KIT, CONSTANT SPEED CONVERSION	2475N5/7.5 W/4-FOOT RECEIVER
81294639	KIT, CONSTANT SPEED CONVERSION	2475N7.5 W/3-FOOT RECEIVER
81294688	KIT, CONSTANT SPEED CONVERSION	2475D5
81295867	KIT, CONSTANT SPEED CONVERSION	2475N5 W/3-FOOT RECEIVER

BATTERY SUPPORT KITS

The Battery Support Kit will allow a battery to be conveniently mounted on the Kohler, Honda and Kawasaki engine driven compressors. The kit contains the battery support, battery hold-down frame and attachment hardware.

CCN	DESCRIPTION	MODELS
32095663	KIT, BATTERY SUPPORT	KOHLER, HONDA, KAWASAKI ENGINE MODELS

VINYL COVERS

Flame retardant vinyl covers are designed to protect gasoline engine compressors from the elements.

CCN	DESCRIPTION	MODELS
97339337	COVER, VINYL	KOHLER, HONDA, KAWASAKI ENGINE MODELS

GENERAL ARRANGEMENT DRAWINGS

BARE COMPRESSOR PUMP

G2111000-04

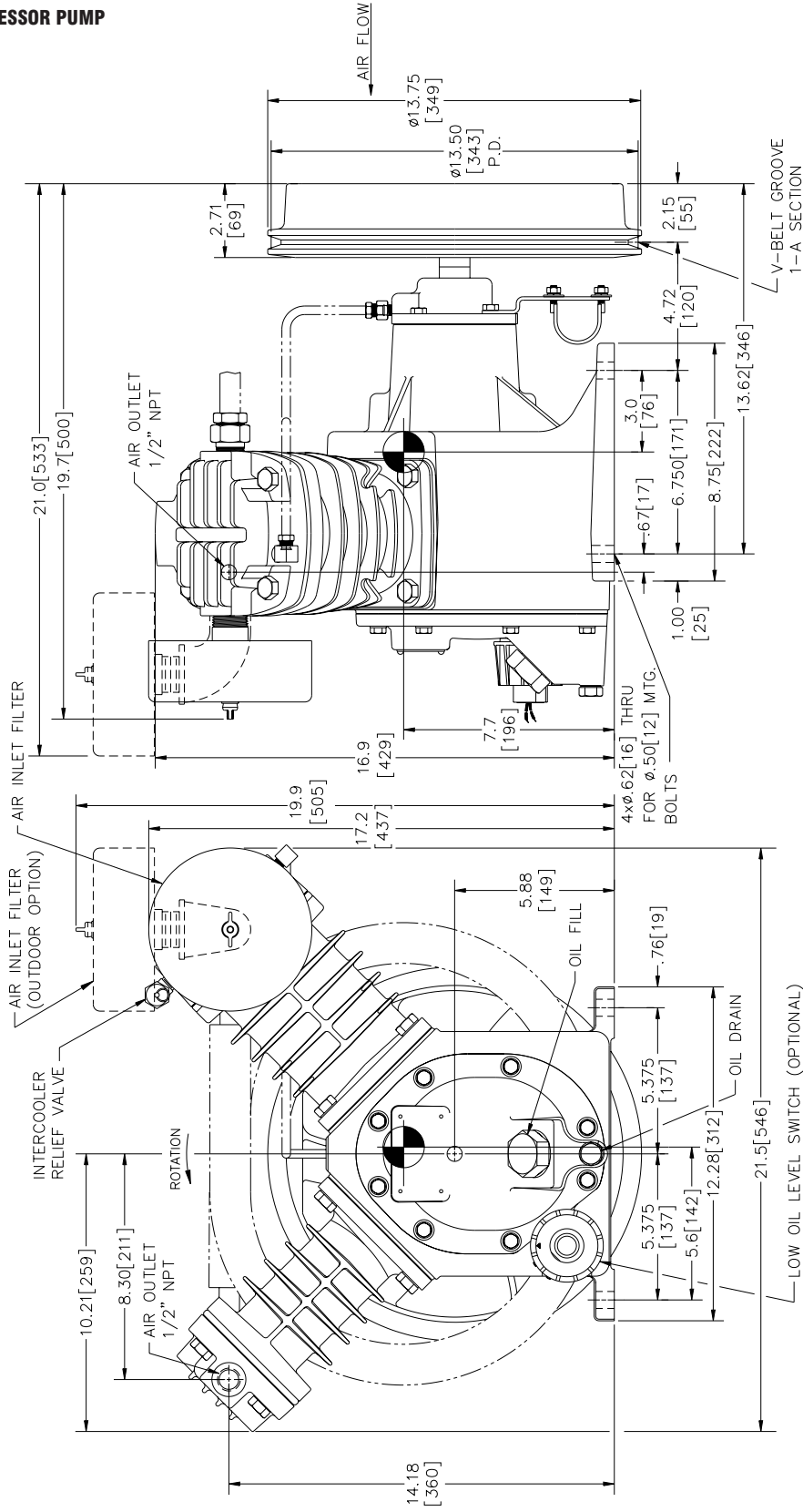

- NOTES:
1. CUSTOMER MUST SUPPLY MTG. ARRANGEMENT WITH AT LEAST 2.00[51] MIN. BELT TAKE-UP.
 2. ALL DIMENSIONS GIVEN IN INCHES.
 3. LEAVE AT LEAST 12.00[305] MIN. CLEARANCE ON ALL SIDES FOR PROPER AIR CIRCULATION.
 4. WEIGHT: 147 LBS.[67kg] DRY (NO LUBRICATION)
 5. ALL UNSPECIFIED TOLERANCES:
 XXX = ±.03[1]
 XX = ±.12[3]
 X = ±.25[6]
 UNLESS OTHERWISE SPECIFIED.
 6. DIMENSIONS IN [] ARE MILLIMETER DIMENSIONS UNLESS OTHERWISE SPECIFIED.

1. CUSTOMER MUST SUPPLY MTG. ARRANGEMENT WITH AT LEAST 2.00[51] MIN. BELT TAKE-UP.
2. ALL DIMENSIONS GIVEN IN INCHES.
3. LEAVE AT LEAST 12.00[305] MIN. CLEARANCE ON ALL SIDES FOR PROPER AIR CIRCULATION.

BASEPLATE MOUNTED UNIT WITH ELECTRIC MOTOR

G2211000-05

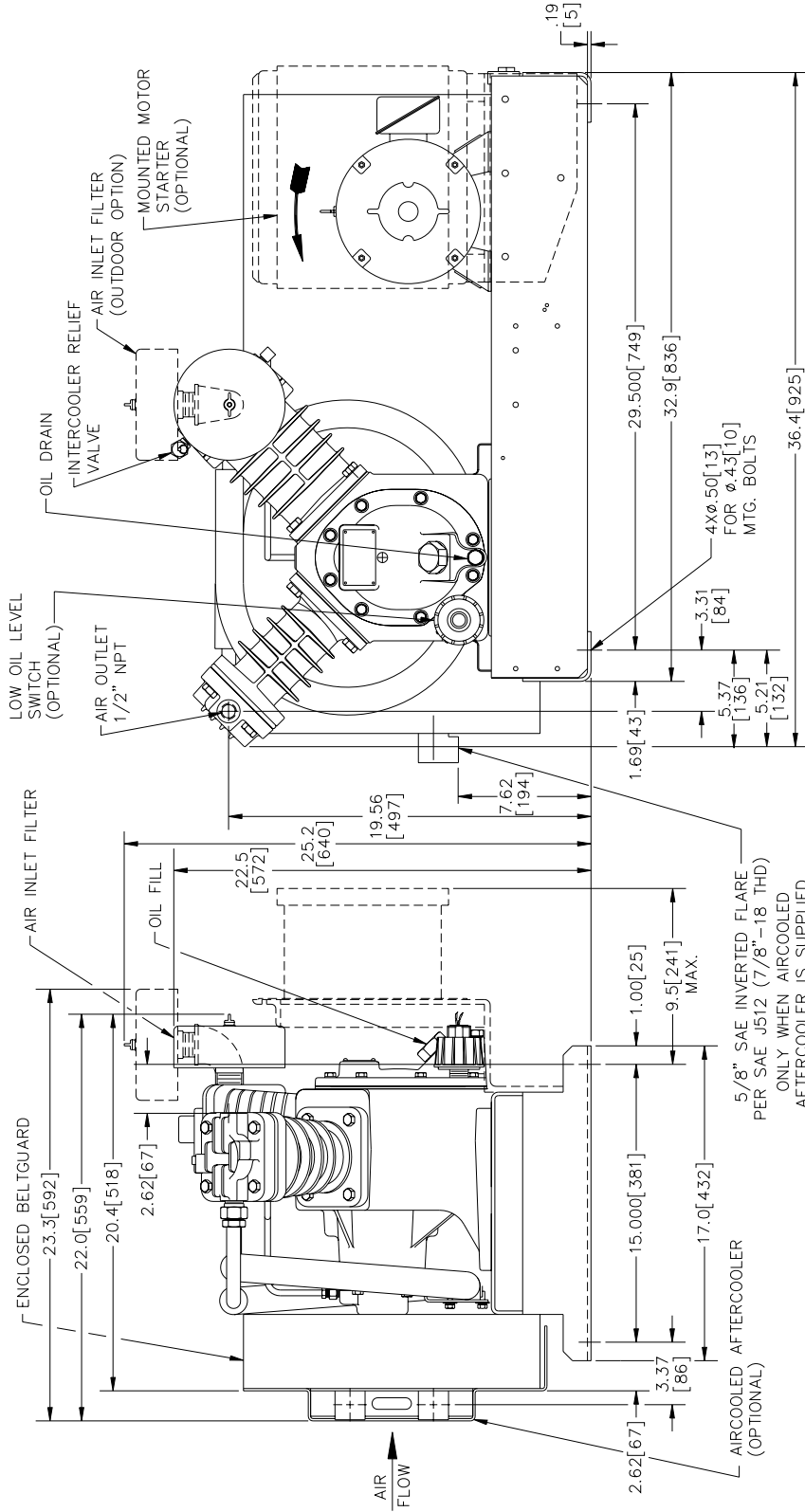

- NOTES:
1. FOUNDATION OR FLOOR MUST BE LEVEL AND SUPPORT ALL FEET EQUALLY; IF NECESSARY SHIM OR GROUT THE FOURTH FOOT.
 2. FOUNDATION BOLTS SHOULD PROJECT THRU NUTS AT LEAST 1/2" [13] TO ALLOW FOR LEVELING.
 3. ALLOW AT LEAST 12.00" [305] CLEARANCE MINIMUM ON ALL SIDES FOR PROPER AIR CIRCULATION.
 4. APPROXIMATE NET WEIGHT: 350 LBS. [159kg]
 5. ALL UNSPECIFIED DIMENSIONS: XXX = .125 [3] XX = .25 [6] X = .50 [13]
 6. DIMENSIONS IN [] ARE MILLIMETER DIMENSIONS UNLESS OTHERWISE SPECIFIED.

80-GALLON HORIZONTAL TANK MOUNTED UNIT

G2311000-05

NOTES:

1. FOUNDATION OR FLOOR MUST BE LEVEL AND SUPPORT ALL FEET EQUALLY; IF NECESSARY SHIM OF GROUT THE FOURTH FOOT.
2. FOUNDATION BOLTS SHOULD PROJECT THRU NUTS AT LEAST 1/2"[13] TO ALLOW FOR LEVELING.
3. ALL UNSPECIFIED TOLERANCES:
 XXX = ±.12[3]
 XX = ±.25[6]
 X = ±.50[13]
4. ALLOW AT LEAST 12.00"[305] CLEARANCE MIN. ON ALL SIDES FOR PROPER AIR CIRCULATION.
5. * = ADD 6.00"[152] WHEN AUTOMATIC CONDENSATE DRAIN VALVE IS SUPPLIED.
6. APPROXIMATE WEIGHT 535 LBS.[243kg]
7. UNITS WITHOUT AFTERCOOLER WILL HAVE WIRE BELTGUARDS.
8. ** = ADD .68[17] FOR WIRE BELTGUARDS.
 *** = ADD .68[17] FOR WIRE BELTGUARDS.
 UNLESS OTHERWISE SPECIFIED.

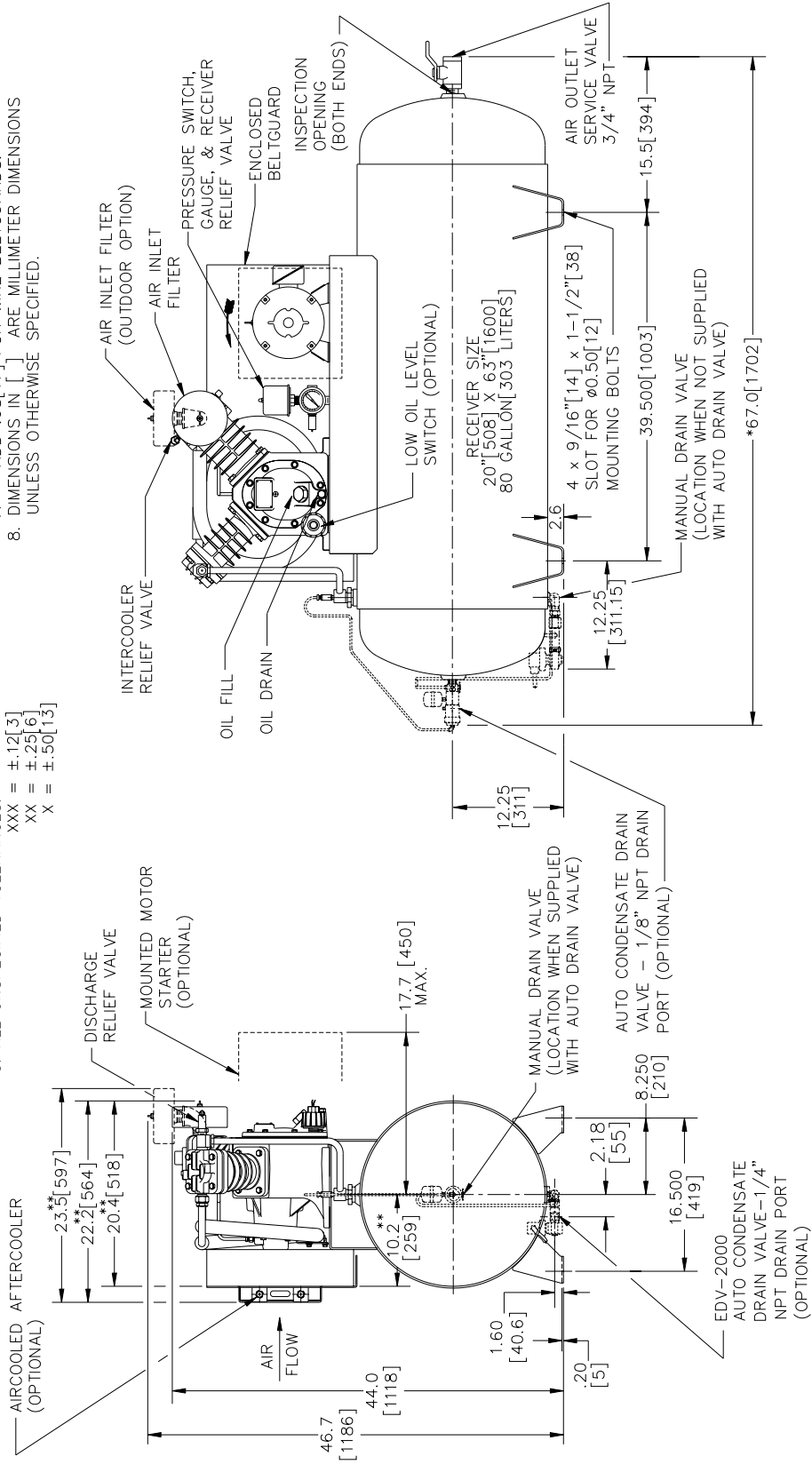

80-GALLON VERTICAL TANK MOUNTED UNIT — FULLY PACKAGED

G2811300-01

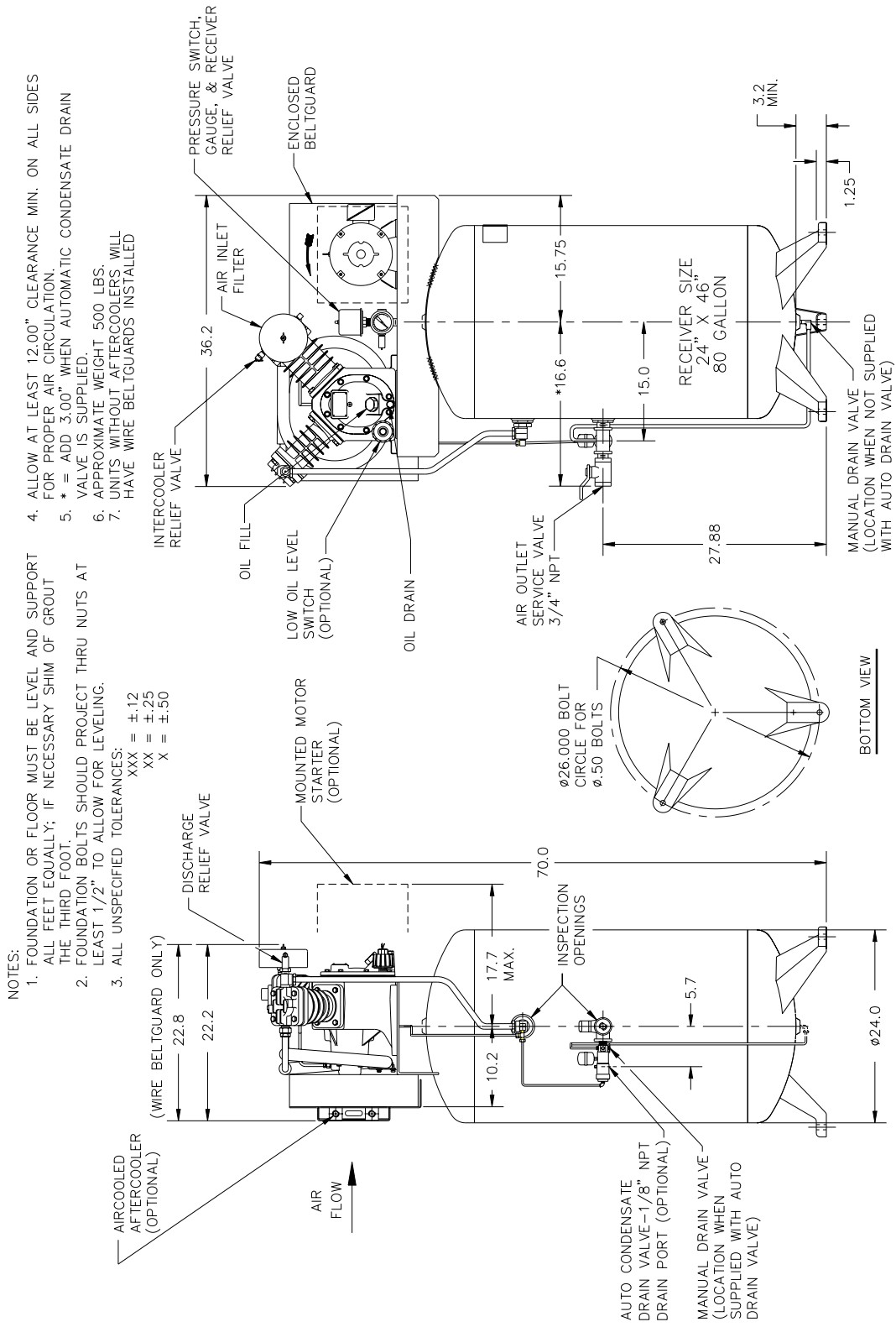

NOTES:

1. FOUNDATION OR FLOOR MUST BE LEVEL AND SUPPORT ALL FEET EQUALLY; IF NECESSARY SHIM OF GROUT THE THIRD FOOT.
2. FOUNDATION BOLTS SHOULD PROJECT THRU NUTS AT LEAST 1/2" TO ALLOW FOR LEVELING.
3. ALL UNSPECIFIED TOLERANCES:
 XXX = $\pm .12$
 XX = $\pm .25$
 X = $\pm .50$
4. ALLOW AT LEAST 12.00" CLEARANCE MIN. ON ALL SIDES FOR PROPER AIR CIRCULATION.
5. * = ADD 3.00" WHEN AUTOMATIC CONDENSATE DRAIN VALVE IS SUPPLIED.
6. APPROXIMATE WEIGHT 500 LBS.
7. UNITS WITHOUT AFTERCoolERS WILL HAVE WIRE BELTGUARDS INSTALLED

80-GALLON VERTICAL TANK MOUNTED UNIT

G2811302-02

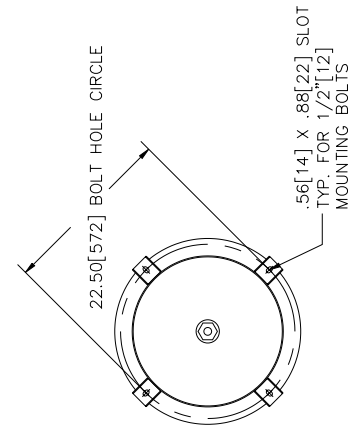
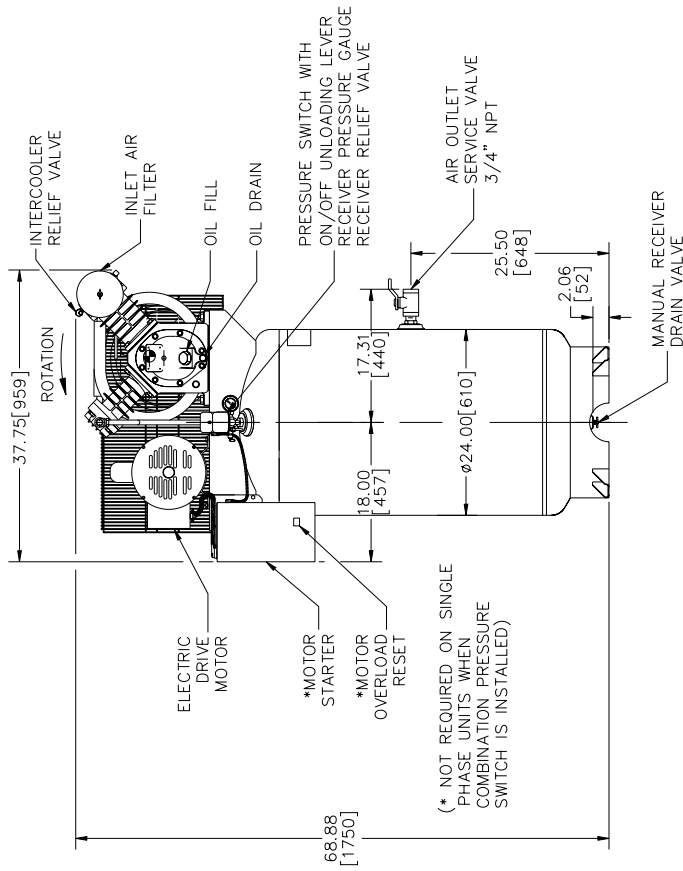
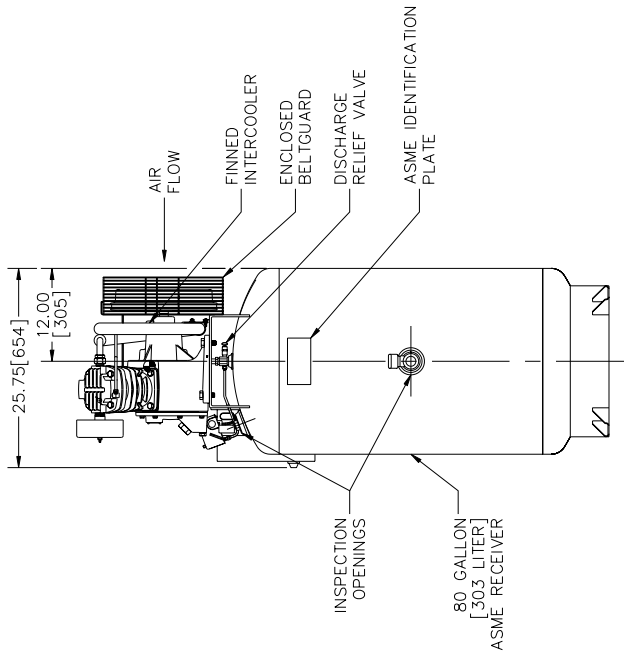

- NOTES:
1. FOUNDATION OR FLOOR MUST BE STRUCTURALLY SOUND, SUPPORT ALL FEET EQUALLY. IF NECESSARY SHIM OR GROUT THE FEET TO LEVEL.
 2. FOUNDATION BOLTS MUST PROJECT THROUGH THE FEET AT LEAST 1/2" [13] TO ALLOW FOR LEVELING
 3. ALL UNSPECIFIED TOLERANCES:
 .XXX = ±.12 [3]
 .XX = ±.25 [6]
 .X = ±.5 [13]
 4. ALLOW AT LEAST 12" [305] ON ALL SIDE OF THE MACHINE TO ALLOW PROPER AIR CIRCULATION AND MAINTENANCE
 5. APPROXIMATE WEIGHT 500 LBS. [227]
 6. DIMENSIONS IN [] ARE MILLIMETER DIMENSIONS UNLESS OTHERWISE SPECIFIED

TANK MOUNTED DUPLEX UNIT WITH 5 HP MOTORS

NOTES:

1. FOUNDATION OR FLOOR MUST BE LEVEL AND SUPPORT ALL FEET EQUALLY; IF NECESSARY SHIM OR GROUT THE FOURTH FOOT.
2. THE COMPRESSOR ARRANGEMENT SHOWN IS REPRESENTATIVE OF ALL THE UNITS LISTED. SPECIFIED ACCESSORY ITEMS ARE NOT NECESSARILY SHOWN BUT WILL NOT INCREASE THE DIMENSION.
3. FOUNDATION BOLTS SHOULD PROJECT THRU NUTS AT LEAST 1/2" [13] TO ALLOW FOR LEVELING.
4. ALLOW AT LEAST 12.00" [305] CLEARANCE MIN. ON ALL SIDES FOR PROPER AIR CIRCULATION.
5. * = ADD ".4" WHEN AUTOMATIC CONDENSATION DRAIN VALVE IS SUPPLIED.
6. ALL UNSPECIFIED TOLERANCES: XXX = ± .12 [3] XX = ± .25 [6] X = ± .50 [13]
7. UNITS WITHOUT AFTERCOOLERS WILL HAVE WIRE BELTGUARDS.
8. DIMENSIONS IN [] ARE MILLIMETER DIMENSIONS UNLESS OTHERWISE SPECIFIED.

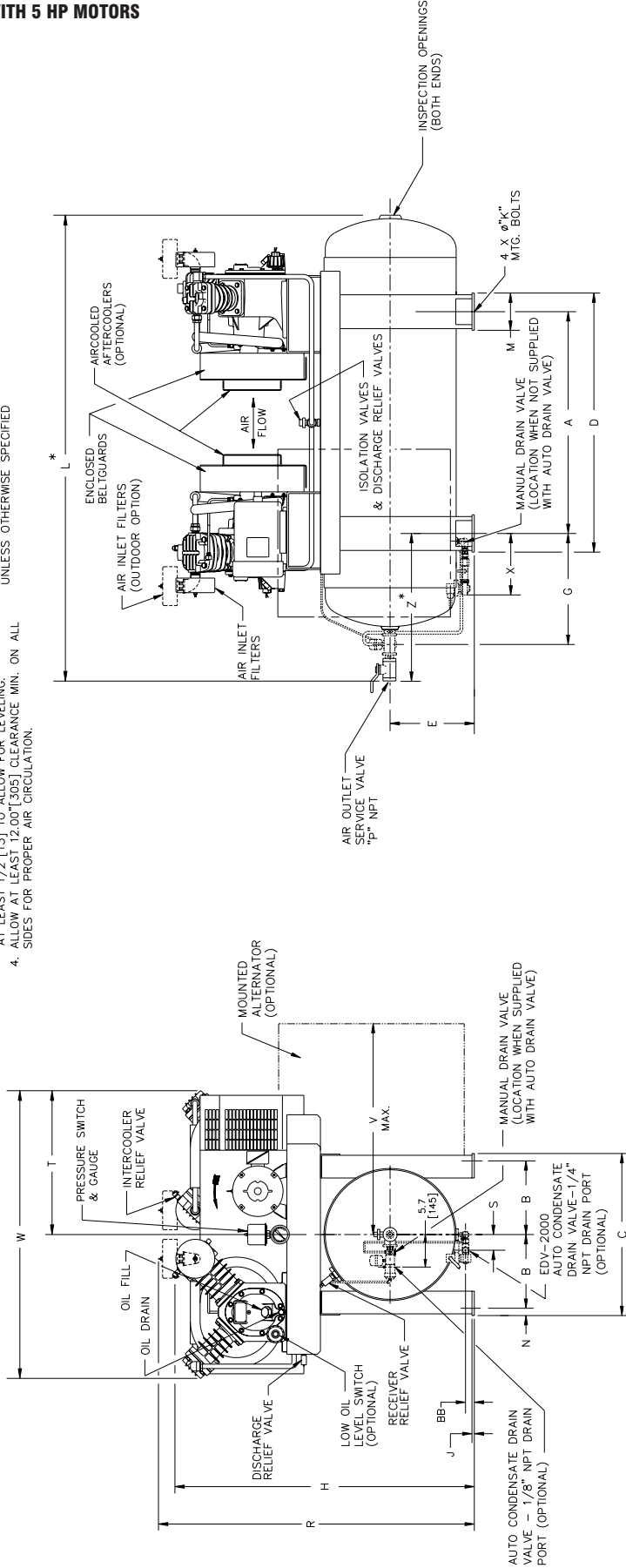

MODEL	NET WT. (kg)	RECEIVER SIZE	GAL [LITER]	DIMENSIONS IN INCHES [MM]																					
				A	B	BB	C	D	E	G	H	J	K	L	M	N	P	R	S	T	V	W	X	Y	Z
2-2475D5	950 [431]	20" x 6 3/4" [508 x 1600]	80 [303]	34.250 [870]	11.375 [289]	1.50 [38]	25.00 [635]	40.50 [1029]	13.00 [330]	16.2 [411]	46.0 [1168]	46.0 [1168]	.38 [10]	.50 [12]	66.1 [1679]	6.25 [159]	1.13 [29]	47.5 [1207]	2.18 [55]	22.2 [564]	35.7 [907]	44.5 [1130]	15.87 [403]	3.00 [76]	17.5 [445]
2-2475E5	1300 [596]	24" x 6 7/8" [610 x 1702]	120 [454]	42.000 [1067]	20.000 [508]	3.44 [87]	42.50 [1080]	50.00 [1270]	17.25 [438]	15.9 [404]	52.6 [1336]	52.6 [1336]	.75 [19]	.62 [16]	72.4 [1839]	8.25 [210]	1.25 [32]	54.1 [1374]	2.18 [55]	22.2 [564]	26.7 [678]	44.5 [1130]	11.50 [292]	4.25 [108]	17.6 [447]

TANK MOUNTED DUPLEX UNIT WITH 7.5 HP MOTORS

G2411301-02

- NOTES: 1. FOUNDATION OF FLOOR MUST BE LEVEL AND SUPPORT ALL FEET EQUALLY; IF NECESSARY SHIM OF GROUT THE FOURTH FOOT.
 2. ACCESSORY ITEMS THAT ARE NOT NECESSARILY SHOWN WILL NOT INCREASE THE OVERALL DIMENSIONS.
 3. MAXIMUM COMPRESSOR RPM @ 1500.
 4. FOUNDATION BOLTS SHOULD PROJECT THRU NUTS AT LEAST 1/2" [13] TO ALLOW FOR LEVELING.
 5. ALLOW AT LEAST 12.00" [305] CLEARANCE MIN. ON ALL SIDES FOR PROPER AIR CIRCULATION.
 6. * = ADD 3.50" [89] WHEN AUTOMATIC CONDENSATE DRAIN VALVE IS SUPPLIED.
 7. ALL UNSPECIFIED TOLERANCES: XXX = ±.125 [3]
 XX = ±.25 [6]
 X = ±.50 [13]
 8. DIMENSIONS IN [] ARE MILLIMETER DIMENSIONS UNLESS OTHERWISE SPECIFIED.

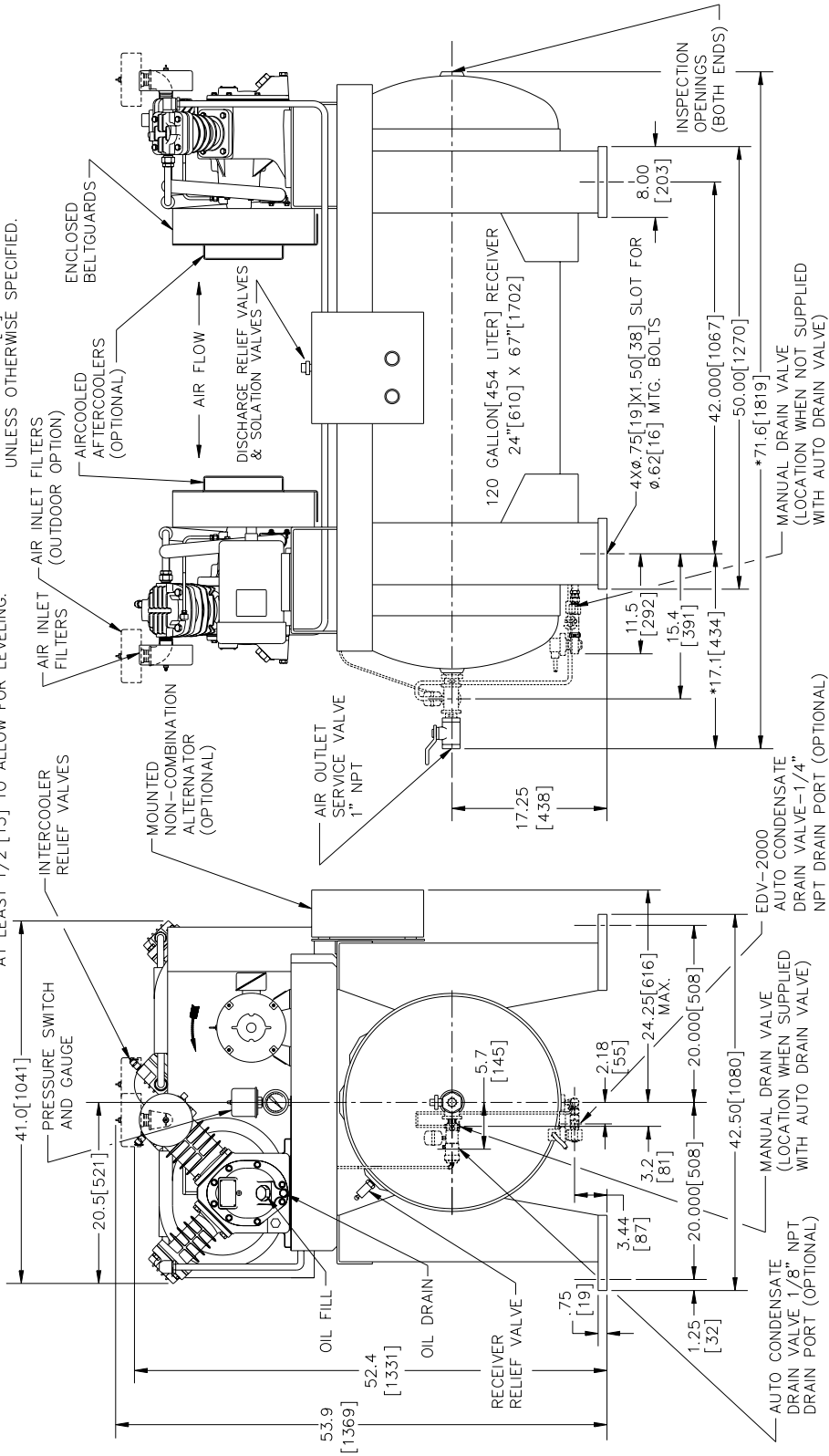

BASEPLATE MOUNTED UNIT WITH KAWASAKI ENGINE

G2611003-01

NOTES:

1. FOUNDATION OR FLOOR MUST BE LEVEL AND SUPPORT ALL FEET EQUALLY; IF NECESSARY SHIM OR GROUT THE FOURTH FOOT.
2. FOUNDATION BOLTS SHOULD PROJECT THRU NUTS AT LEAST 1/2" [13] TO ALLOW FOR LEVELING.
3. ALLOW AT LEAST 12.00 [305] CLEARANCE MIN. ON ALL SIDES FOR PROPER AIR CIRCULATION.
4. ALL UNSPECIFIED TOLERANCES: XXX = ±.12 [3]
XX = ±.25 [6]
X = ±.50 [13]
5. DIMENSIONS IN [] ARE MILLIMETER DIMENSIONS UNLESS OTHERWISE SPECIFIED.

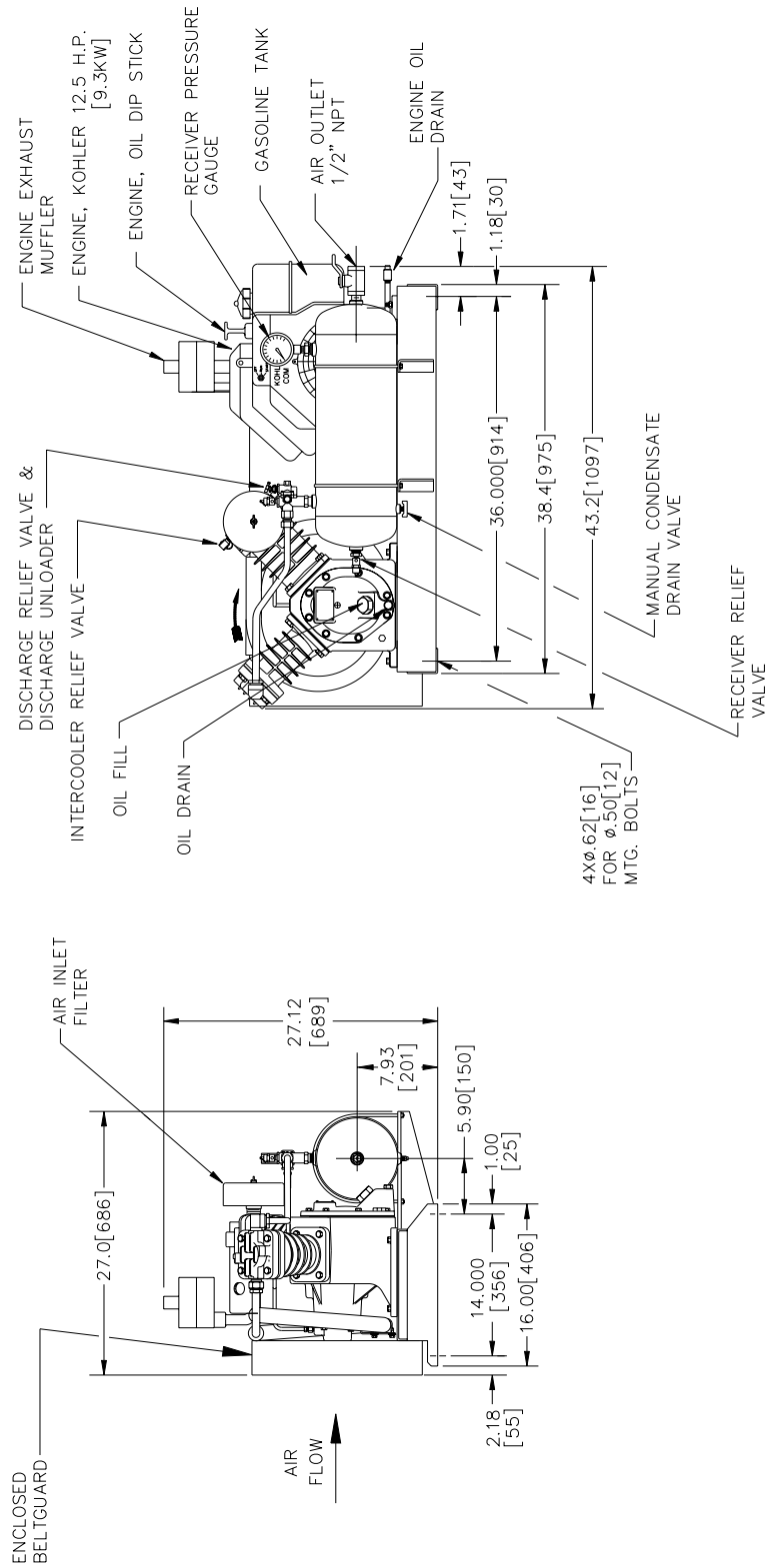

TANK MOUNTED UNIT WITH KOHLER ENGINE

G2711004-01

NOTES:

1. FOUNDATION OR FLOOR MUST BE LEVEL AND SUPPORT ALL FEET EQUALLY; IF NECESSARY SHIM OR GROUT THE FOURTH FOOT.
2. FOUNDATION BOLTS SHOULD PROJECT THRU NUTS AT LEAST 1/2"[13] TO ALLOW FOR LEVELING.
3. ALLOW AT LEAST 12.00[305] CLEARANCE MIN. ON ALL SIDES FOR PROPER AIR CIRCULATION.
4. ALL UNSPECIFIED TOLERANCES: XXX = ±.12[3]
XX = ±.25[6]
X = ±.50[13]
5. DIMENSIONS IN [] ARE MILLIMETER DIMENSIONS UNLESS OTHERWISE SPECIFIED.

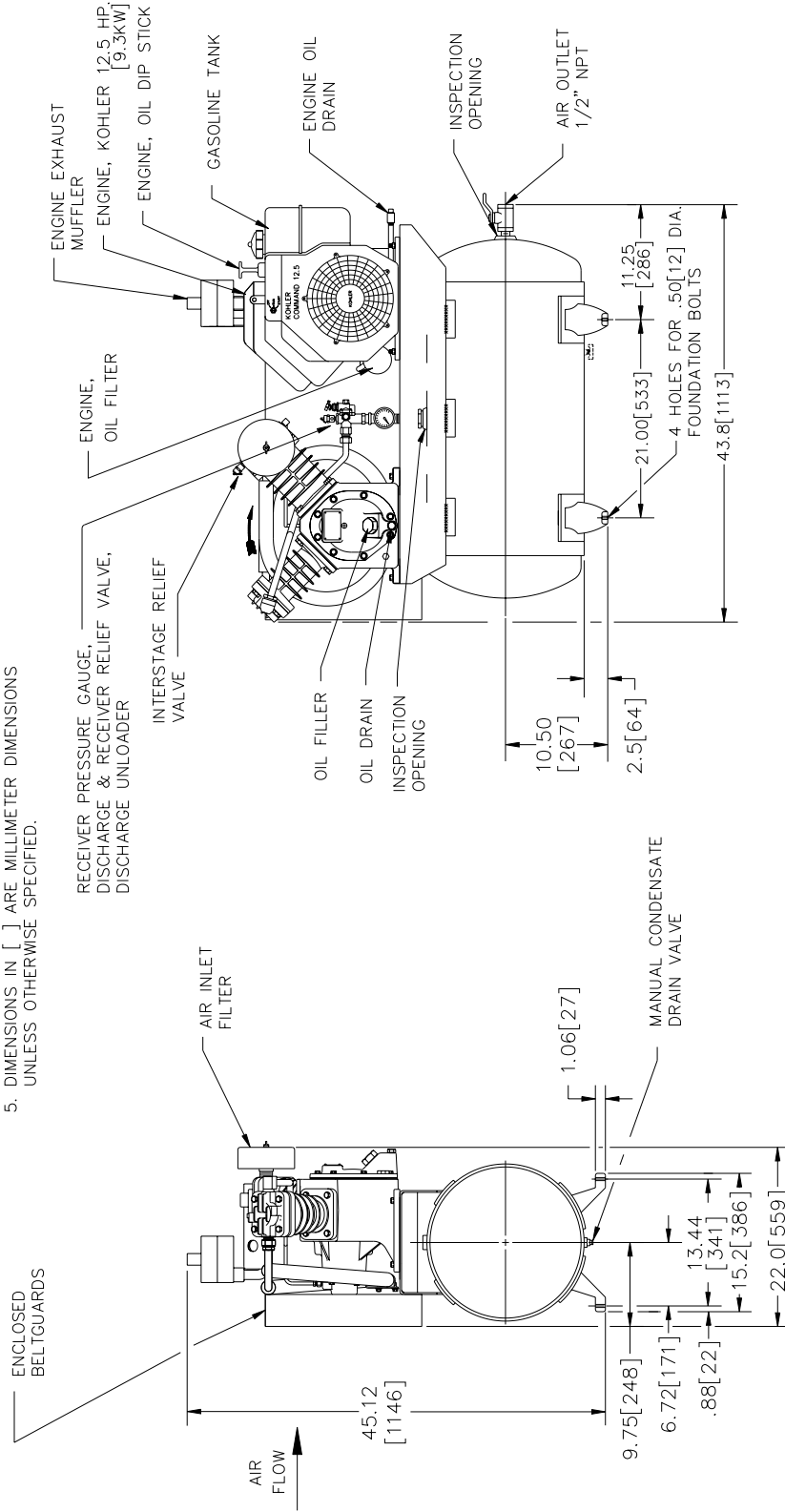

BASEPLATE MOUNTED UNIT WITH KAWASAKI ENGINE

G2611002-00

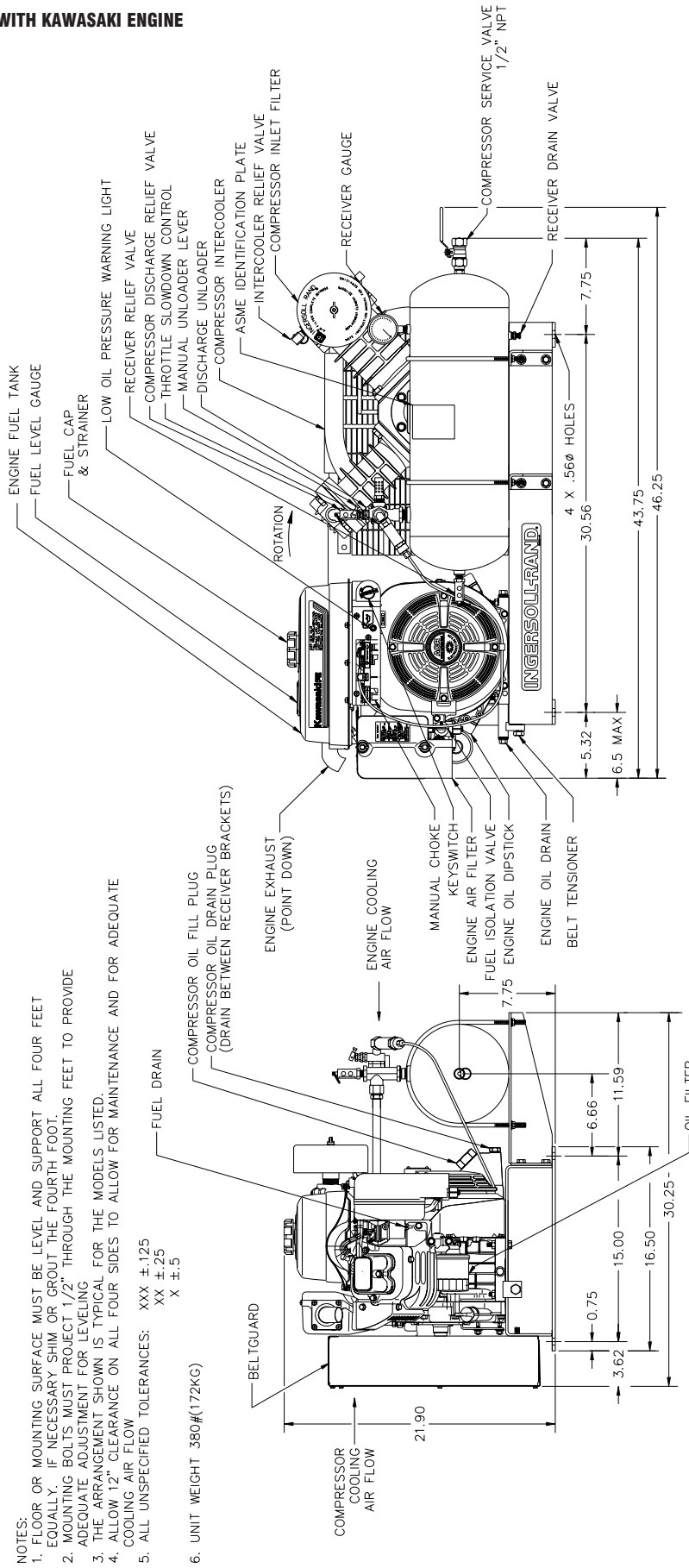

- NOTES:
1. FLOOR OR MOUNTING SURFACE MUST BE LEVEL AND SUPPORT ALL FOUR FEET EQUALLY. IF NECESSARY SHIM OR GROUT THE FOURTH FOOT.
 2. MOUNTING BOLTS MUST PROJECT 1/2" THROUGH THE MOUNTING FEET TO PROVIDE ADEQUATE ADJUSTMENT FOR LEVELING.
 3. THE ARRANGEMENT SHOWN IS TYPICAL FOR THE MODELS LISTED.
 4. ALLOW 12" CLEARANCE ON ALL FOUR SIDES TO ALLOW FOR MAINTENANCE AND FOR ADEQUATE COOLING AIR FLOW.
 5. ALL UNSPECIFIED TOLERANCES: XXX \pm .125
XX \pm .25
X \pm .5
 6. UNIT WEIGHT 380#(172KG)

TANK MOUNTED UNIT WITH KAWASAKI ENGINE

G2711003-01

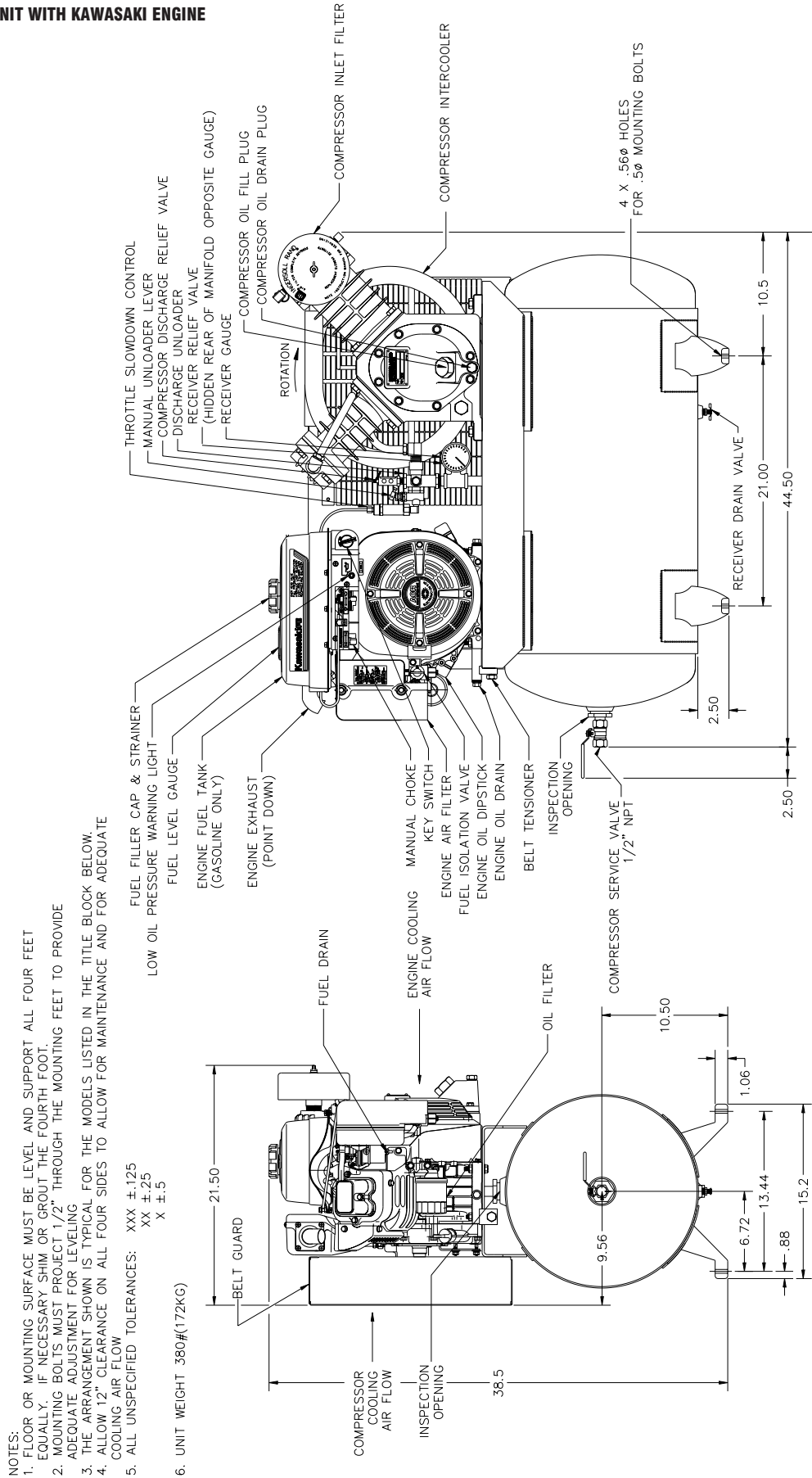

BASEPLATE MOUNTED UNIT WITH HONDA ENGINE

NOTES:

1. FOUNDATION OR FLOOR MUST BE LEVEL AND SUPPORT ALL FEET EQUALLY; IF NECESSARY SHIM OR GROUT THE FOURTH FOOT.
2. FOUNDATION BOLTS SHOULD PROJECT THRU NUTS AT LEAST 1/2 [13] TO ALLOW FOR LEVELING.
3. ALLOW AT LEAST 12.00 [305] CLEARANCE MIN. ON ALL SIDES FOR PROPER AIR CIRCULATION.
4. ALL UNSPECIFIED TOLERANCES: XXX = ±.12 [3] XX = ±.25 [6] X = ±.50 [13]
5. DIMENSIONS IN [] ARE MILLIMETER DIMENSIONS UNLESS OTHERWISE SPECIFIED.

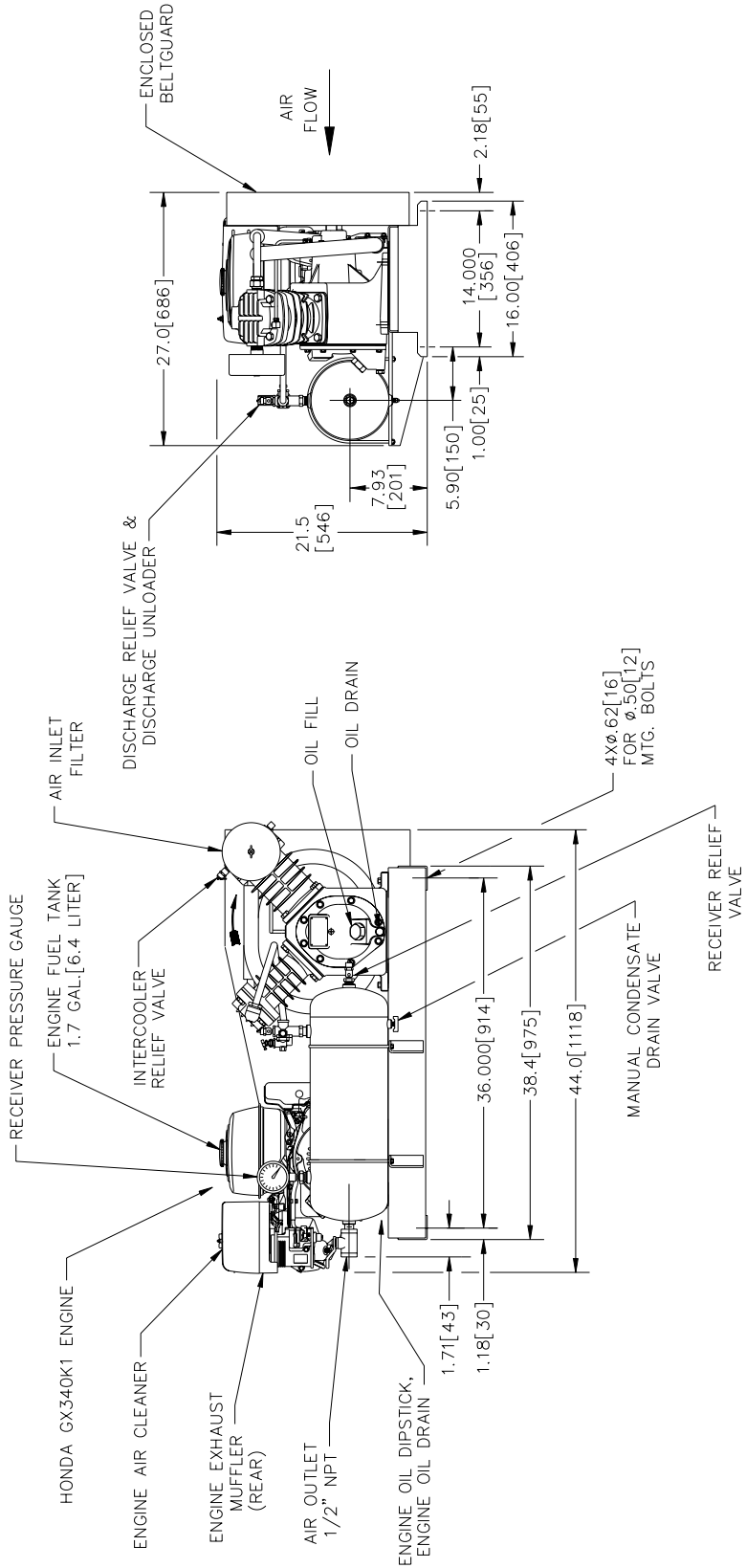

TANK MOUNTED UNIT WITH HONDA ENGINE

G2711000-02

NOTES:

1. FOUNDATION OR FLOOR MUST BE LEVEL AND SUPPORT ALL FEET EQUALLY; IF NECESSARY SHIM OR GROUT THE FOURTH FOOT.
2. FOUNDATION BOLTS SHOULD PROJECT THRU NUTS AT LEAST 1/2"[13] TO ALLOW FOR LEVELING.
3. UNIT MUST BE INSTALLED WITH 32308652 ISOLATION MOUNTS BETWEEN FEET & MOUNTING STRUCTURE.
4. ALLOW AT LEAST 12.00[305] CLEARANCE MIN. ON ALL SIDES FOR PROPER AIR CIRCULATION.
5. ALL UNSPECIFIED TOLERANCES: XX = ±.25[6]
X = ±.50[13]
6. DIMENSIONS IN [] ARE MILLIMETER DIMENSIONS UNLESS OTHERWISE SPECIFIED.

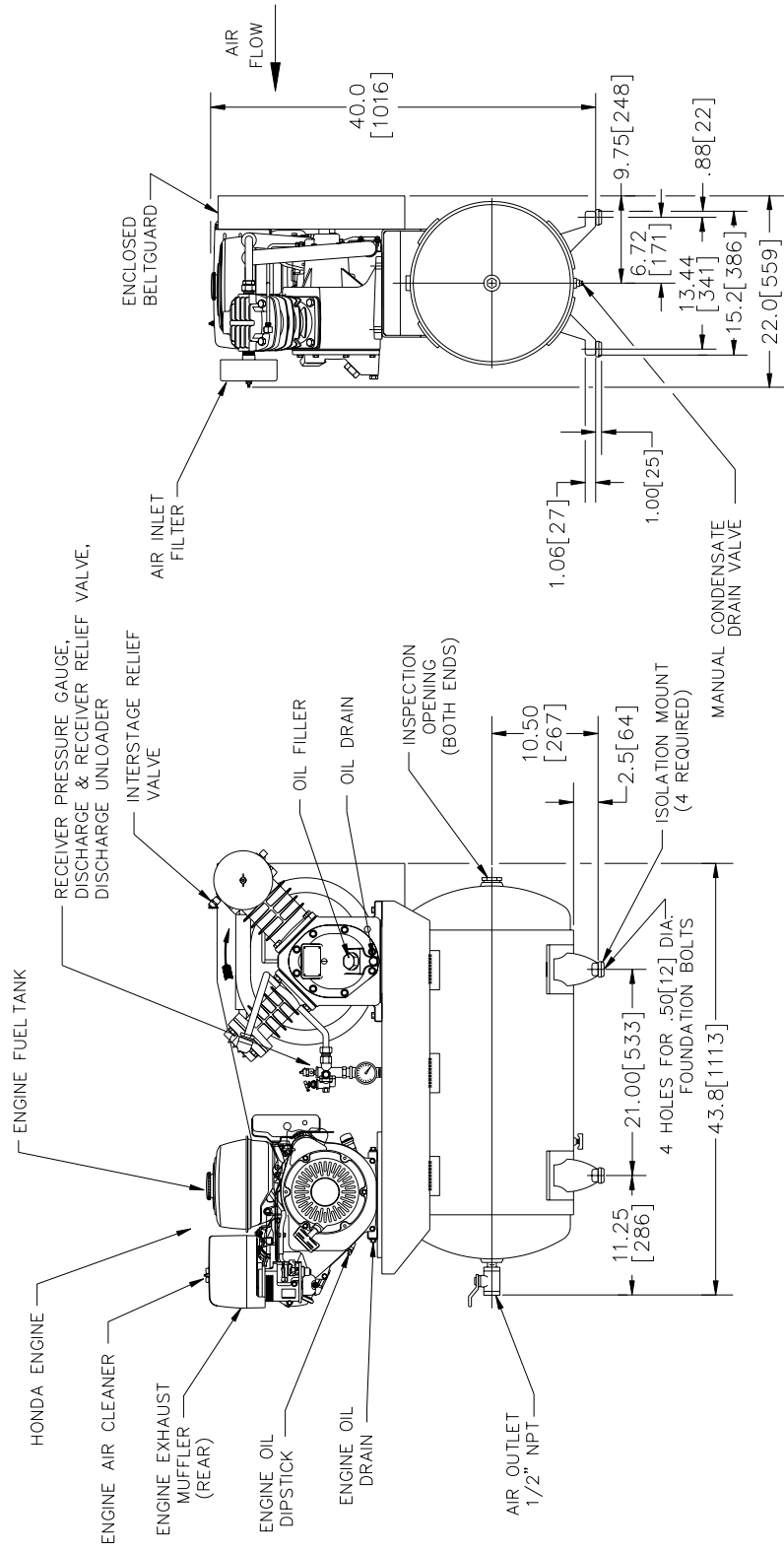



A series of horizontal lines for writing, starting from the top right of the pen icon and extending across the width of the page. The lines are evenly spaced and cover the majority of the page's vertical space.



A series of horizontal lines for writing, starting from the top right of the pen icon and extending across the width of the page. The lines are evenly spaced and cover the majority of the page's vertical space, providing a template for handwriting practice.

LOOK WHAT INGERSOLL-RAND CAN DO FOR YOU!



Efficient Field Service

We maintain a highly trained staff of technicians to service your equipment for preventive maintenance, or to assist you should emergencies ever occur.

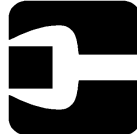

Complete Repair Service

Our trained technicians will repair or overhaul your equipment to factory specifications, using only genuine I-R parts.



Special Engineering Service

We can help you identify and solve your problems by evaluating your needs and recommending the proper equipment to give you maximum efficiency.



Spare Parts

By stocking genuine I-R spare parts, we can help you avoid costly delays or substituting inferior parts. Using genuine I-R parts on your I-R equipment will help to keep even older equipment running in good-as-new condition.



Complete Stock of Equipment

We carry a complete line of I-R equipment and accessories designed to meet any compressed air application. We are backed by I-R's prompt factory shipment to ensure you on-time delivery.

A SUBSTITUTE IS NOT A REPLACEMENT!

Ensure you get peak performance and longevity out of your Ingersoll-Rand product by insisting on genuine Ingersoll-Rand replacement parts and maintenance kits. Not only are the replacement parts made to precise dimensions and OEM-specified metallurgy, but each part is backed by the Ingersoll-Rand warranty. Your local Air Center, Distributor, or direct Ingersoll-Rand salesperson will work with you to ensure you get the parts you need to do the job right. Equip your machines with only the best — Ingersoll-Rand genuine parts.

NOTE: THE USE OF REPAIR PARTS OTHER THAN THOSE INCLUDED WITHIN THE INGERSOLL-RAND COMPANY APPROVED PARTS LIST MAY CREATE UNSAFE CONDITIONS OR MECHANICAL FAILURES OVER WHICH INGERSOLL-RAND COMPANY HAS NO CONTROL. INGERSOLL-RAND COMPANY SHALL BEAR NO RESPONSIBILITY FOR EQUIPMENT ON WHICH NON-APPROVED REPAIR PARTS ARE INSTALLED.

