

PARTS LIST

T30 MODEL 2340
TWO STAGE
INDUSTRIAL
AIR COMPRESSOR



A series of horizontal lines spanning the width of the page, designed for writing. The lines are evenly spaced and cover the majority of the page area.



A series of horizontal lines for writing, starting from the top right of the pen icon and extending across the width of the page. The lines are evenly spaced and cover most of the page's height.

FIGURE 1. COMPRESSOR FRAME ASSEMBLY.

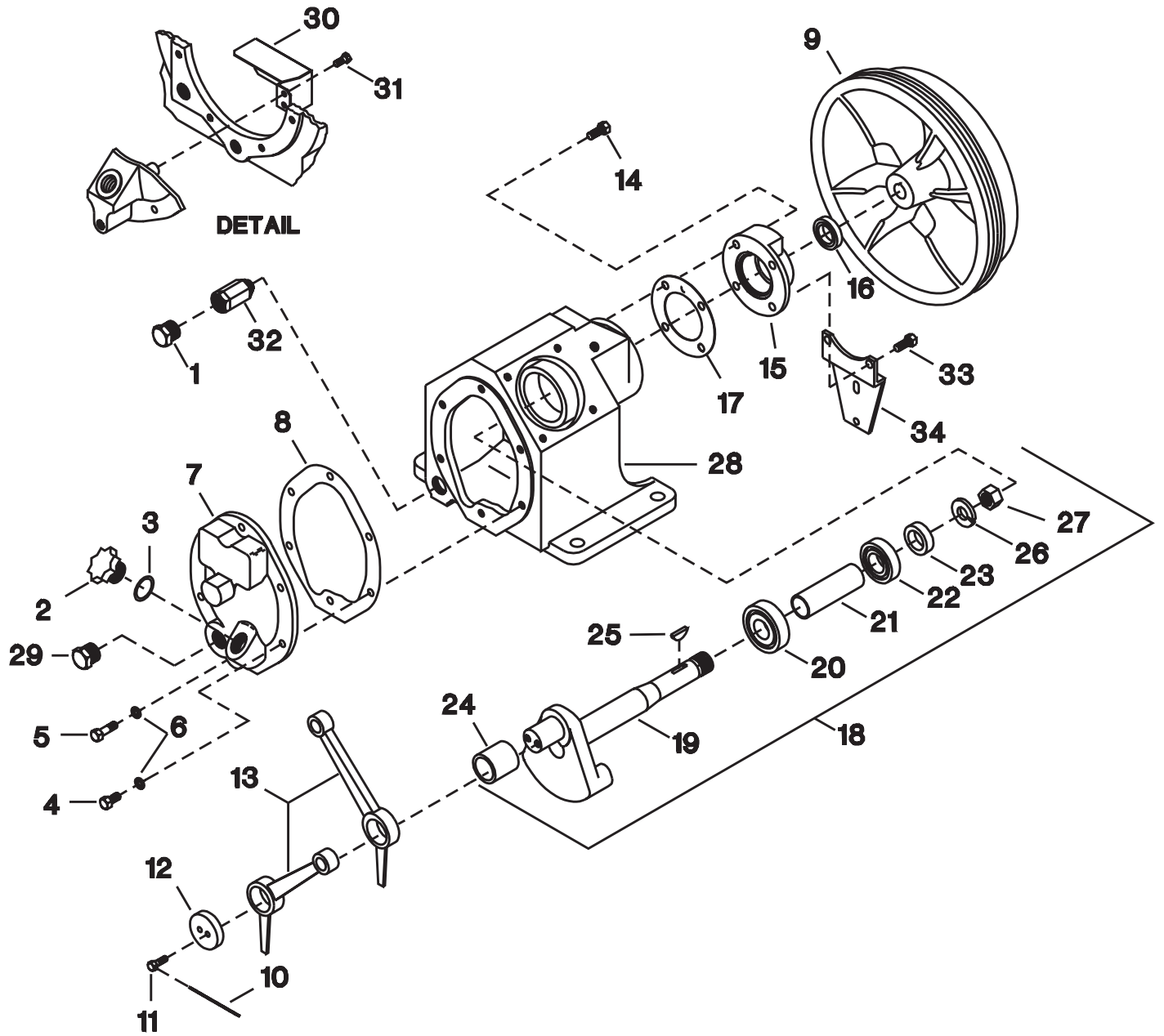

REF. NO.	PART NO.	DESCRIPTION	QTY.	SPARES		
				1	2	3
1-1	95033601	PLUG, PIPE - HEX HEAD - 3/8"	1			
1-2	37127065	PLUG, OIL FILLER	1			
1-3	95022158	O-RING	1	1	1	2
1-4	95105243	CAPSCREW, HEX HEAD - 5/16-18x7/8"	5			
1-5	95002978	CAPSCREW, HEX HEAD - 5/16-18x1-1/4"	1			
1-6	95674651	GASKET, COPPER WASHER	6			
1-7	37127123	COVER, FRAME END	1			
1-8	32293680	GASKET, FRAME END COVER	1	1	1	2
1-9	32498974	BELTWHEEL (CLOCKWISE ROTATION WHEN FACING UNIT)	1			
1-9	32293698	BELTWHEEL (COUNTER-CLOCKWISE ROTATION WHEN FACING UNIT)	1			
1-10	90799289	LOCKWIRE, 12 GA - 5"	1			
1-11	30278709	CAPSCREW, LOCK - 1/4-20x3/4"	2			
1-12	30210314	CAP, CRANKPIN	1			
1-13	32004145	ROD, CONNECTING	2		2	2
1-14	95105243	CAPSCREW, HEX - 5/16-18x7/8"	2			
1-15	37127032	COVER, SHAFT END	1			
1-16	32204521	SEAL, OIL	1			
1-17	32293672	GASKET, SHAFT END COVER	1	1	1	2
1-18	32496549	CRANKSHAFT, COMPLETE	1			
1-19	32293821	• ASSY, DISC/SHAFT	1			
1-20	95930400	• BEARING, BALL	1			
1-21	37127016	• SPACER, CRANKSHAFT BEARING	1			
1-22	95951216	• BEARING, BALL - W/SNAP RING	1			
1-23	37127024	• RING, BEARING RETAINER	1			
1-24	30289813	• BUSHING, CRANKPIN	1			
1-25	95433173	• KEY, WOODRUFF	1			
1-26	95081790	• LOCKWASHER - 5/8"	1			
1-27	95076808	• NUT, HEX - 5/8-18	1			
1-28	30222327	FRAME, COMPRESSOR	1			
1-29	95200333	PLUG, PIPE - HEX HEAD - 3/4"	1			
1-30	32270639	BAFFLE, OIL LEVEL (SEE NOTE)	1			
1-31	95053070	CAPSCREW, HEX - 1/4 - 20 X 1/2" (SEE NOTE)	2			
1-32	70235049	ADAPTER, DRAIN EXTENSION (SEE NOTE)	1			
1-33	95105243	CAPSCREW, HEX - 5/16 - 18 X 7/8" (SEE NOTE)	2			
1-34	97331011	BRACKET, INTERCOOLER CLAMP	1			

NOTE: ITEMS 30, 31, 32 & 33 PROVIDED IF LOW OIL LEVEL SWITCH IS SUPPLIED.

FIGURE 2. HIGH PRESSURE VALVE PLATE ASSEMBLY.

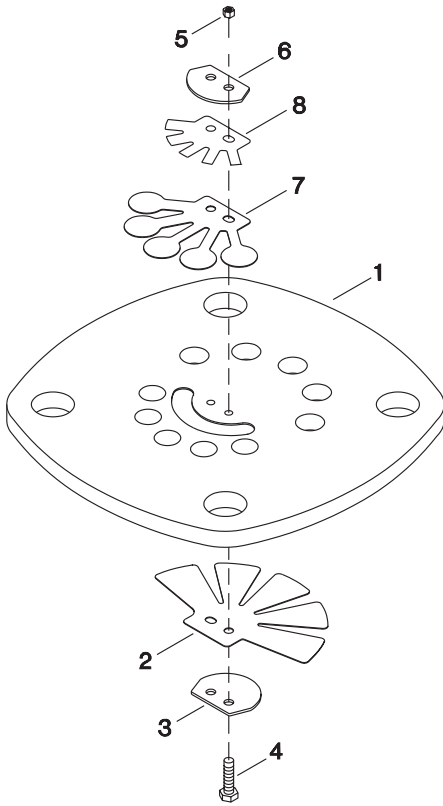
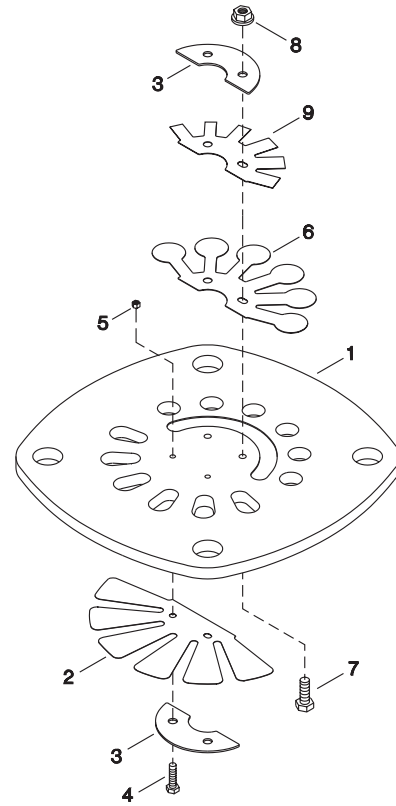

FIGURE 3. LOW PRESSURE VALVE PLATE ASSEMBLY.



REF. NO.	PART NO.	DESCRIPTION	QTY.	SPARES		
				1	2	3
REF.	32310799	ASSY, VALVE PLATE - HP	1			
2-1	NSS	PLATE, VALVE - HP	1			
2-2	32236671	VALVE, FINGER - HP INLET	1			
2-3	32297343	RETAINER, VALVE - HP	1			
2-4	32297327	SCREW, M3 x 12	2			
2-5	97511059	NUT, HEX - M3 W/ LOCKWASHER	2			
2-6	32295461	RETAINER, VALVE - HP	1			
2-7	32241010	VALVE, FINGER - HP DISCHARGE	1			
2-8	32295479	DAMPER, VALVE	1			

REF. NO.	PART NO.	DESCRIPTION	QTY.	SPARES		
				1	2	3
REF.	32310807	ASSY, VALVE PLATE - LP	1			
3-1	NSS	PLATE, VALVE - LP	1			
3-2	32241002	VALVE, FINGER - LP INLET	1			
3-3	97511091	RETAINER, VALVE - LP	2			
3-4	32297327	SCREW, M3 x 12	2			
3-5	97511059	NUT, HEX - M3 W/ LOCKWASHER	2			
3-6	32241036	VALVE, FINGER - LP DISCHARGE	1			
3-7	32247512	SCREW, M4 x 12 HEX HEAD	2			
3-8	32248171	NUT, M4 HEX	2			
3-9	32294472	DAMPER, VALVE	1			

FIGURE 4. MODEL 2340 BARE COMPRESSOR.

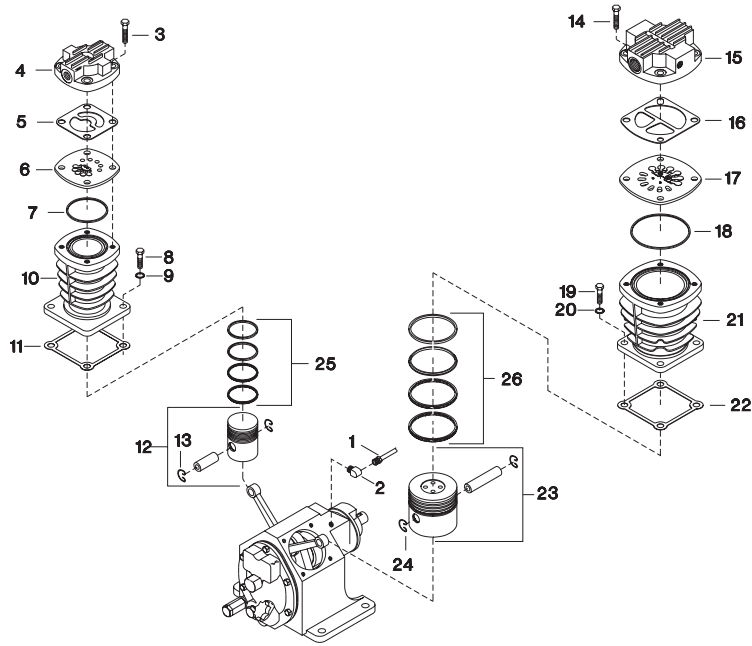

REF. NO.	PART NO.	DESCRIPTION	QTY.	SPARES		
				1	2	3
4-1	32295651	ASSY., TUBE - BREATHER	1			
4-2	95031860	ELBOW, TUBE - 5/16x1/8"	2			
4-3	95104188	CAPSCREW, HEX - 1/2-13x1-3/4"	4			
4-4	32247827	HEAD, HP	1			
4-5	32247926	GASKET, HEAD - HP	1	1	1	2
4-6	REF.	ASSY., VALVE PLATE - HP (SEE FIGURE 2)	1		1	1
4-7	32246878	O-RING - HP	1		1	1
4-8	95035333	CAPSCREW, HEX - 3/8-16x1"	4			
4-9	95674677	GASKET, COPPER - 3/8"	4			
4-10	32294415	CYLINDER, AIR - HP	1			
4-11	32293623	GASKET, FLANGE	1	1	1	2
4-12	32496606	ASSY., HP PISTON - COMPLETE	1		1	1
4-13	35151067	• RING, LOCK	2			
4-14	95104188	CAPSCREW, HEX - 1/2-13x1-3/4"	4			
4-15	32247694	HEAD, LP	1			
4-16	32247934	GASKET, HEAD - LP	1	1	1	2
4-17	REF.	ASSY., VALVE PLATE - LP (SEE FIGURE 3)	1		1	1
4-18	32246910	O-RING - LP	1		1	1
4-19	95035333	CAPSCREW, HEX - 3/8-16x1"	4			
4-20	95674677	GASKET, COPPER - 3/8"	4			
4-21	32293656	CYLINDER - LP	1			
4-22	32293623	GASKET, FLANGE	1	1	1	2
4-23	32496572	ASSY., LP PISTON - COMPLETE	1		1	1
4-24	35151067	• RING, LOCK	2			
4-25	37138237	SET, RING - HP	1			
4-26	32194276	SET, RING - LP	1			

FIGURE 5. INTERCOOLER ASSEMBLY & TUBING. (CLOCKWISE ROTATING UNIT SHOWN BELOW.)

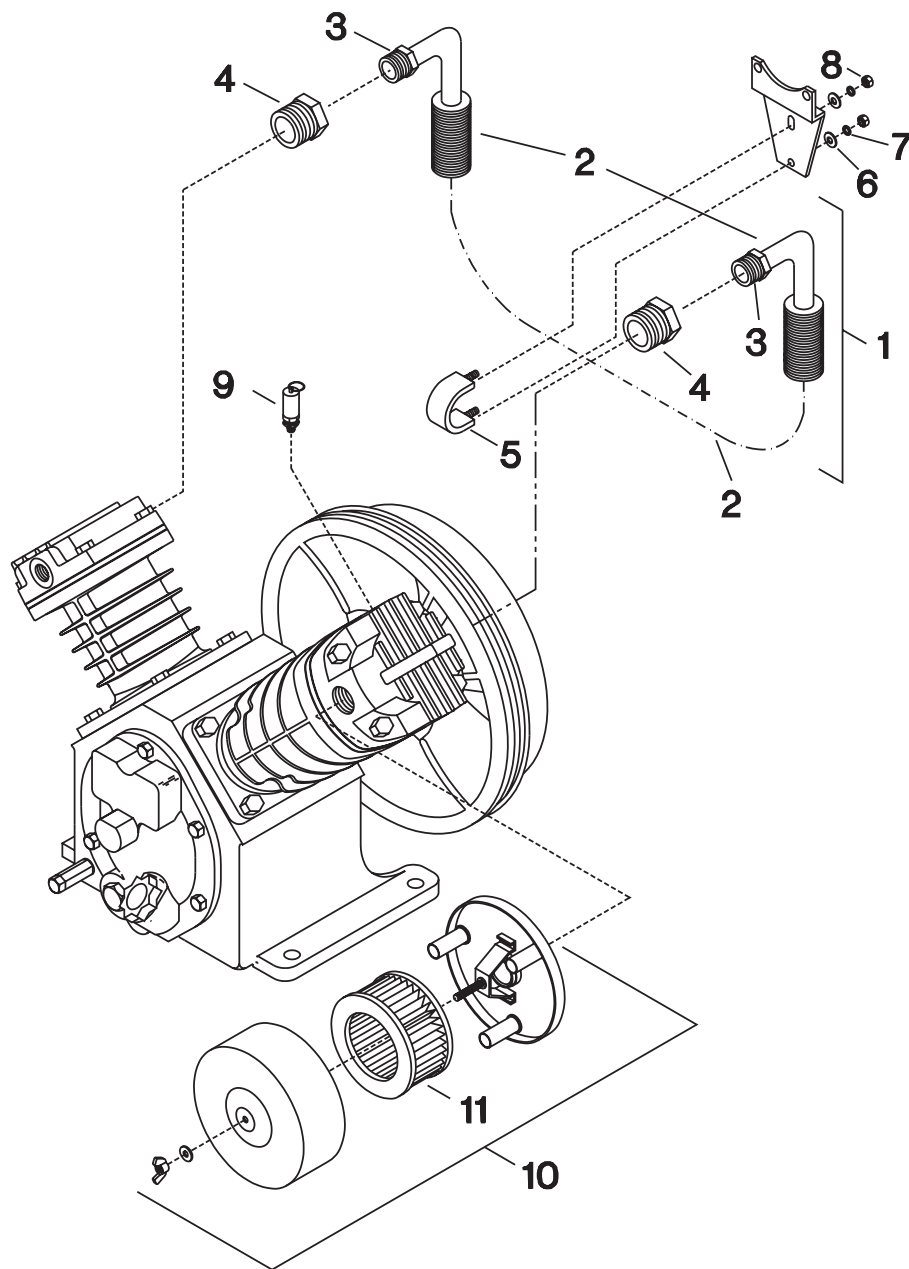

REF. NO.	CLOCKWISE PART NO.	COUNTER-CLOCKWISE PART NO.	DESCRIPTION	QTY.	SPARES		
					1	2	3
5-1	97331003	32293706	ASSY., INTERCOOLER	1		1	1
5-2	97330997	32295545	• INTERCOOLER	1			
5-3	95108577	95108577	• NUT, TUBE - 3/4"	2			
5-4	95083275	95031761	CONNECTOR, TUBE - 3/4" x 3/4"	2			
5-5	32247942	N/A	CLAMP, INTERCOOLER	1			
5-6	95094298	N/A	WASHER, FLAT - 1/4"	2			
5-7	32035479	N/A	LOCKWASHER, SPRING - 1/4"	2			
5-8	95416335	N/A	NUT, HEX - 1/4-20	2			
5-9	72062185	72062185	VALVE, RELIEF - 80 PSIG	1			
5-10	32170953	32170953	FILTER, INLET - COMPLETE	1		1	2
5-11	32170979	32170979	• ELEMENT, FILTER - 10 MICRON	1	1	1	1

FIGURE 6. TYPICAL BASEPLATE MOUNTED ELECTRIC PACKAGES.

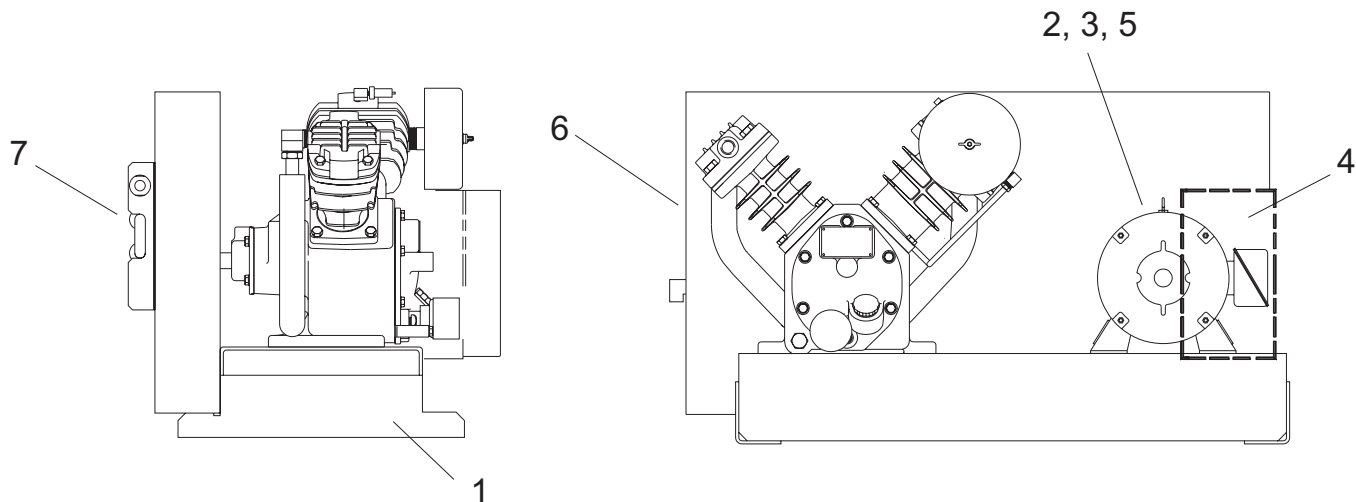

REF. NO.	PART NUMBER (QTY.)				DESCRIPTION	QTY.
	2340X2	2340X3	H2340X2	H2340X3		
6-1	32195224	32195224	32195224	32195224	ASSEMBLY, SUBBASE	1
6-2	32037566 **	32036592 **	32037566 **	32036592 **	MOTOR, ELECTRIC	1
6-3	32110660 **	32281768 **	32110660 **	32281768 **	PULLEY, MOTOR	1
6-4	32190019 **	32190076 **	32190019 **	32190076 **	STARTER (IF SUPPLIED)	1
6-5	95099503 **	95099503 **	95099503 **	95099503 **	BELT, DRIVE	1
6-6	REF.	REF.	REF.	REF.	BELTGUARD — SHEET METAL TYPE (SEE FIG. 10, PG. 16)	1
6-6	REF.	REF.	REF.	REF.	BELTGUARD — WIRE TYPE (SEE FIG. 9, PG. 14)	1
6-7	REF.	REF.	REF.	REF.	AFTERCOOLER, AIR COOLED (SEE FIG. 10, PG. 16)	1

** = PART NUMBER VARIES. PROVIDE MODEL NUMBER, SERIAL NUMBER AND COMPLETE MOTOR NAMEPLATE DATA WHEN ORDERING.

ACAC = AIR COOLED AFTERCOOLER

REF. = REFERENCE PAGE NUMBER(S) GIVEN IN DESCRIPTION COLUMN.

NOTE: ACAC CANNOT BE MOUNTED ON WIRE BELTGUARD

FIGURE 7. TYPICAL SIMPLEX RECEIVER MOUNTED ELECTRIC PACKAGES.

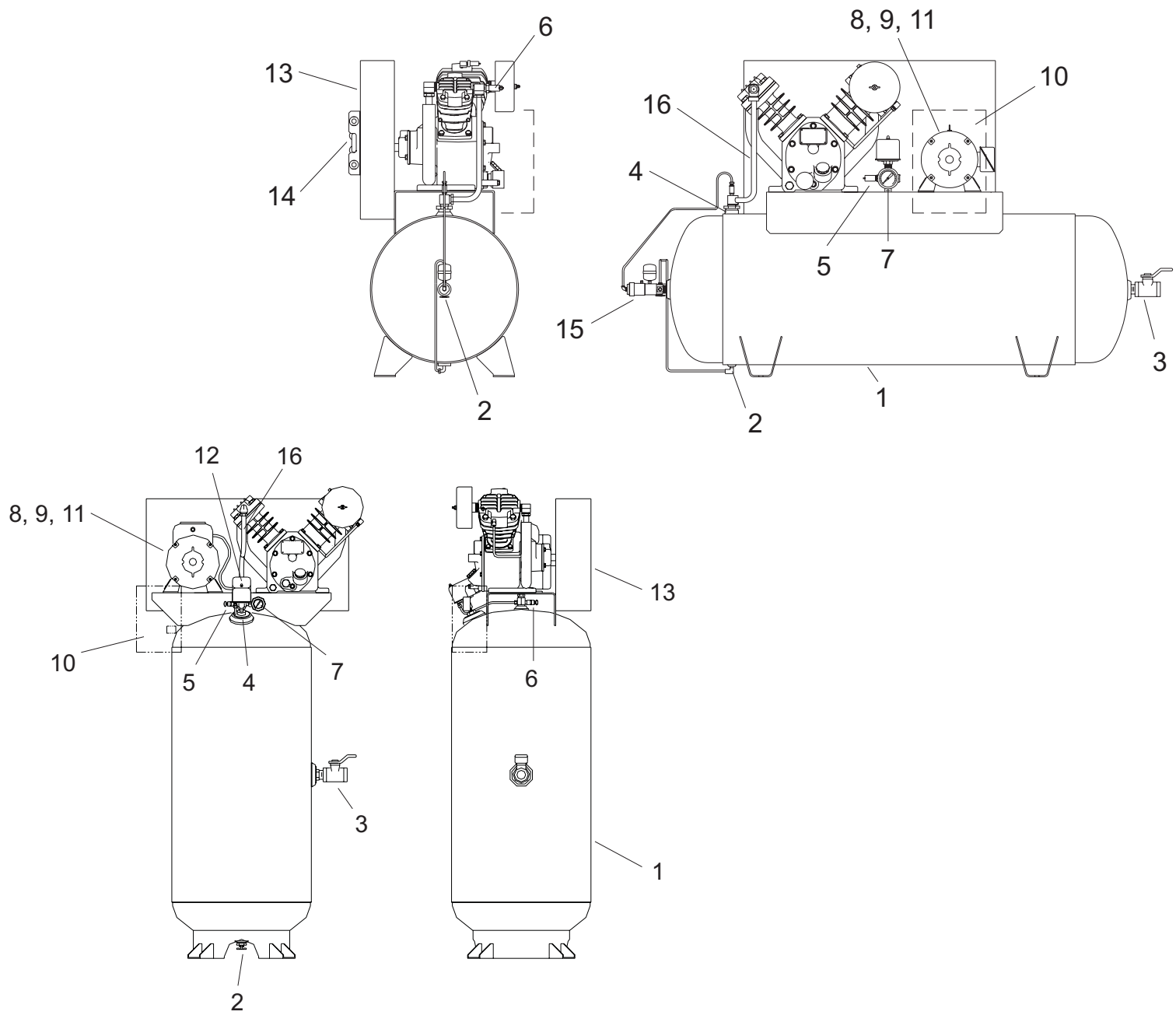

REF. NO.	PART NUMBER (QTY.)				DESCRIPTION	QTY.	
	2340D2	2340N2	2340D3	H2340D3	2340N3	2340L5	
7-1	32498768	32496499	32498768	32251837	32496499	32498933	ASSEMBLY, RECEIVER
7-2	32027120	32027120	32027120	32027120	32027120	32027120	VALVE, MANUAL DRAIN
7-3	32223596	32223596	32223596	32223596	32223596	32223596	VALVE, BALL — SERVICE VALVE
7-4	97162812	97162812	97162812	97162812	97162812	97333165	VALVE, CHECK
7-5	31385693	31385693	31385693	32174799	31385693	31385693	VALVE, SAFETY/RELIEF — RECEIVER
7-6	32174286	32174286	32174286	32174286	32174286	32174286	VALVE, SAFETY/RELIEF — DISCHARGE
7-7	32013872	32013872	32013872	32013872	32013872	32499816	GAUGE, PRESSURE — 300 PSIG
7-8	32037566 **	32037566 **	32036592 **	32036592 **	32036592 **	32295529 **	MOTOR, ELECTRIC — 230/460-3-60 ODP
7-9	32110660 **	32110660 **	32281768 **	32281768 **	32281768 **	32184350 **	PULLEY, MOTOR
7-10	32190019 **	32190019 **	32190076 **	32190076 **	32190076 **	32496903 **	STARTER (IF SUPPLIED) — NEMA 4 230-3-60
7-11	95099503 **	95099503 **	95099503 **	95099503 **	95099503 **	95099503 **	BELT, DRIVE
7-12	37005907	37005907	37005907	37005907	37005907	++	SWITCH, PRESSURE — NEMA 1
7-13	REF.	REF.	REF.	REF.	REF.	REF.	BELTGUARD — SHEET METAL TYPE (SEE FIG. 10, PG. 16)
7-13	REF.	REF.	REF.	REF.	REF.	REF.	BELTGUARD — WIRE TYPE (SEE FIG. 9, PG. 14)
7-14	REF.	REF.	REF.	REF.	REF.	REF.	AFTERCOOLER, AIR COOLED (SEE FIG. 10, PG. 16) +++
7-15	REF.	REF.	REF.	REF.	REF.	REF.	VALVE, AUTOMATIC DRAIN (IF SUPPLIED. SEE FIG. 11, PG. 18)
7-16	32312266	32312274	32312266	32312266	32312274	32498180	ASSEMBLY, TUBE - COMPRESSOR TO RECEIVER

** = PART NUMBER VARIES. SUPPLY MODEL NUMBER, SERIAL NUMBER AND COMPLETE MOTOR NAMEPLATE DATA WHEN ORDERING.

REF. = REFERENCE PAGE NUMBER(S) GIVEN IN DESCRIPTION COLUMN.

ACAC = AIR COOLED AFTERCOOLER

++ = USE 32498891 FOR SINGLE PHASE MOTOR; USE 32147738 FOR THREE-PHASE MOTOR

+++ = ACAC CANNOT BE MOUNTED ON WIRE BELTGUARD.

FIGURE 8. TYPICAL DUPLEX RECEIVER MOUNTED ELECTRIC PACKAGES.

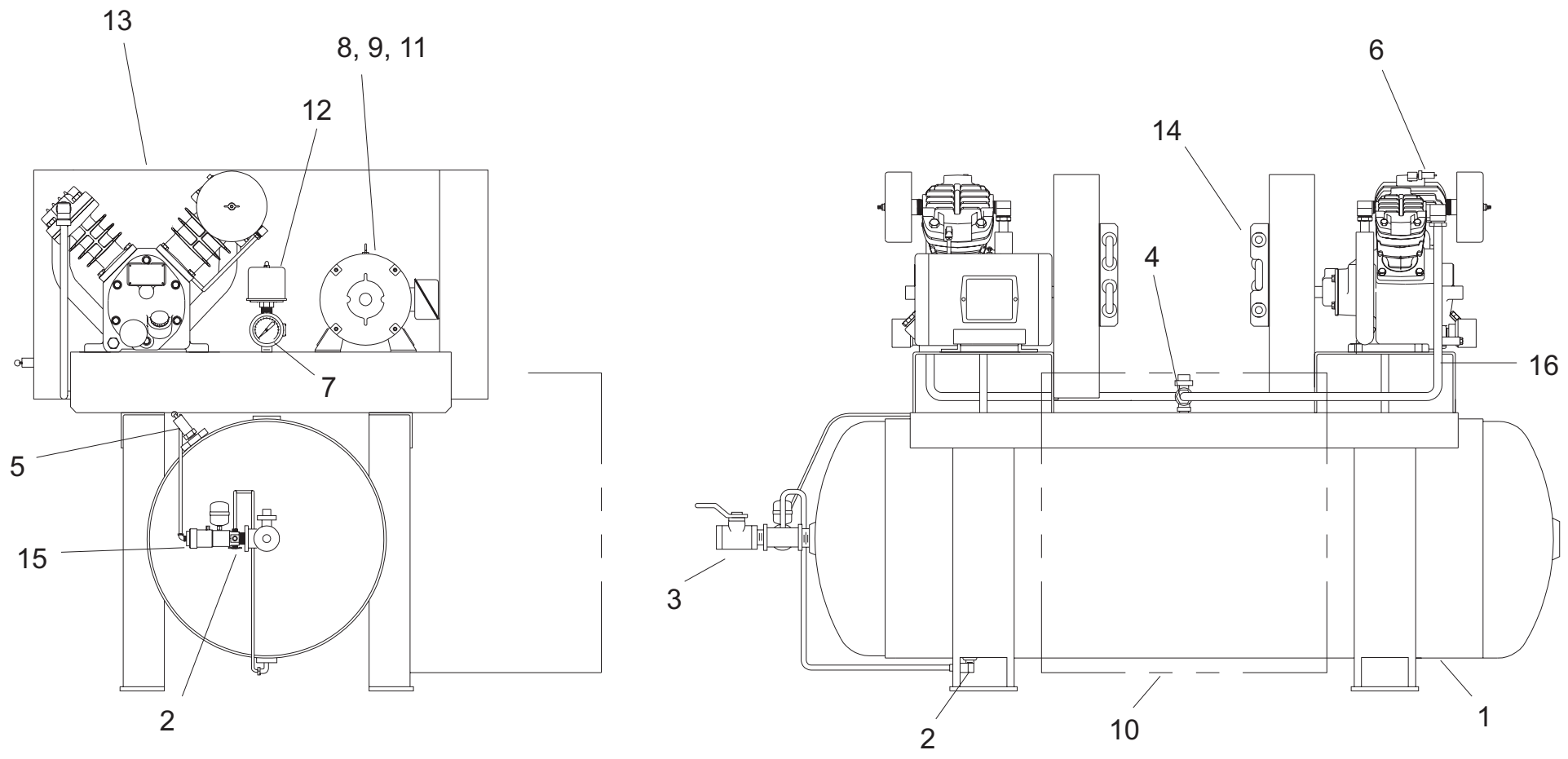

REF. NO.	PART NUMBER (QTY.)	DESCRIPTION	QTY.
	2-2340D2	2-2340D3	
8-1	32251894	32251894 ASSEMBLY, RECEIVER	1
8-2	32027120	32027120 VALVE, MANUAL DRAIN	1
8-3	32223596	32223596 VALVE, BALL — SERVICE VALVE	1
8-4	97162812	97162812 VALVE, CHECK	1
8-5	31385693	31385693 VALVE, SAFETY/RELIEF — RECEIVER (200 PSIG)	1
8-6	32174286	32174286 VALVE, SAFETY/RELIEF — DISCHARGE (325 PSIG)	2
8-7	32499816	32499816 GAUGE, PRESSURE — 300 PSIG	2
8-8	32037566 **	32036592 ** MOTOR, ELECTRIC — 230/460-3-60 ODP	2
8-9	32110660 **	32281768 ** PULLEY, MOTOR	2
8-10	32237133 **	32237141 ** ALTERNATOR (IF SUPPLIED) — 230-3-60	1
8-11	95099503 **	95099503 ** BELT, DRIVE	2
8-12	37005907	37005907 SWITCH, PRESSURE — NEMA 1 (175 PSIG)	2
8-13	REF.	REF. BELTGUARD — SHEET METAL TYPE (SEE FIG. 10, PG. 16)	2
8-13	REF.	REF. BELTGUARD — WIRE TYPE (SEE FIG. 9, PG. 14)	2
8-14	REF.	REF. AFTERCOOLER, AIR COOLED (SEE FIG. 10, PG. 16) +++	2
8-15	REF.	REF. VALVE, AUTOMATIC DRAIN (IF SUPPLIED. SEE FIG. 11, PG. 18)	1
8-16	32312282	32312282 ASSEMBLY, TUBE — COMPRESSOR TO RECEIVER	2

** = PART NUMBER VARIES. SUPPLY MODEL NUMBER, SERIAL NUMBER AND COMPLETE MOTOR NAMEPLATE DATA WHEN ORDERING.

ACAC = AIR COOLED AFTERCOOLER

REF. = REFERENCE PAGE NUMBER(S) GIVEN IN DESCRIPTION COLUMN.

++ = USE32498891 FOR SINGLE PHASE MOTOR; USE 32147738 FOR THREE-PHASE MOTOR

+++ = AIR COOLED AFTERCOOLER CANNOT BE MOUNTED ON WIRE BELTGUARD.

FIGURE 9. TYPICAL WIRE BELTGUARD.

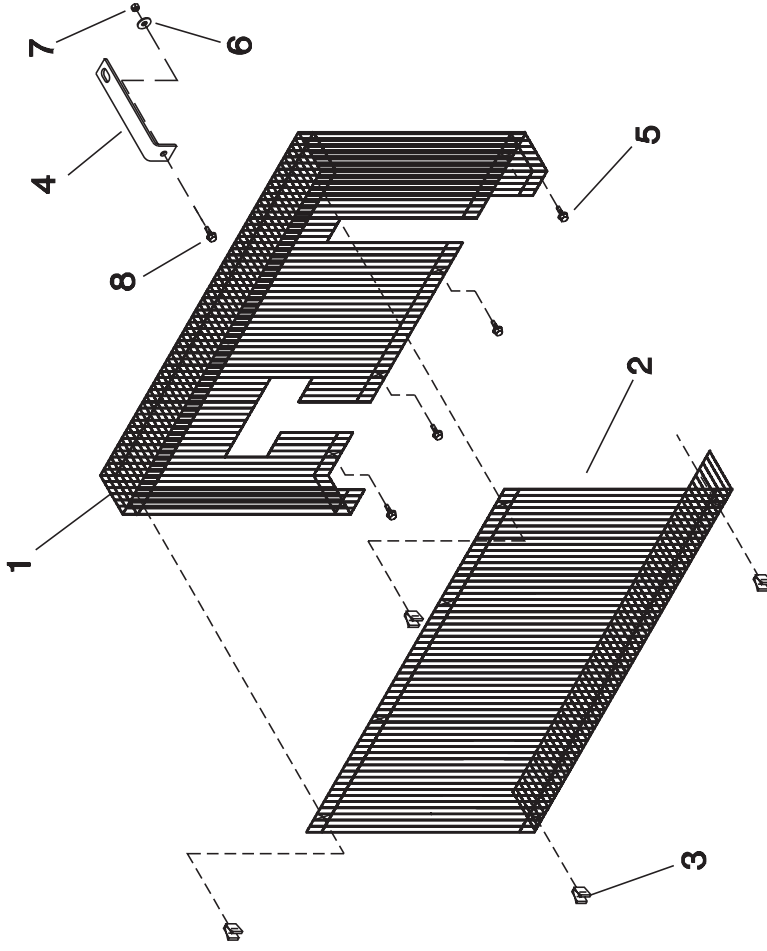

REF. NO.	PART NUMBER (QTY.)	DESCRIPTION			
2340X2	2340D2	2340N2	2-2340D2		
H2340X2	2340D3	2340N3	2-2340D3		
2340X3	H2340D3				
H2340X3					
9-1	32310872 (1)	32499162 (1)	32310872 (1)	32310872 (2)	BACK, BELTGUARD — WIRE TYPE BELTGUARD
9-2	32310880 (1)	32499170 (1)	32310880 (1)	32310880 (2)	COVER, BELTGUARD — WIRE TYPE BELTGUARD
9-3	32496093 (4)	32496093 (4)	32496093 (4)	32496093 (4)	CLIP, PLASTIC — WIRE TYPE BELTGUARD
9-4	32295321 (1)	32295321 (1)	32295321 (1)	32295321 (1)	BRACE, BELTGUARD — WIRE TYPE BELTGUARD
9-5	32164634 (5)	97331458 (4)	32164634 (5)	32164634 (5)	CAPSCREW
9-6	95294278 (5)	95294278 (1)	95294278 (5)	95294278 (5)	WASHER
9-7	39128558 (5)	39128558 (1)	39128558 (5)	39128558 (5)	NUT, WHIZ-LOCK
9-8	—	—	—	—	CAPSCREW

(This page intentionally left blank)

FIGURE 10. BELTGUARD & AIR COOLED AFTERCOOLER.

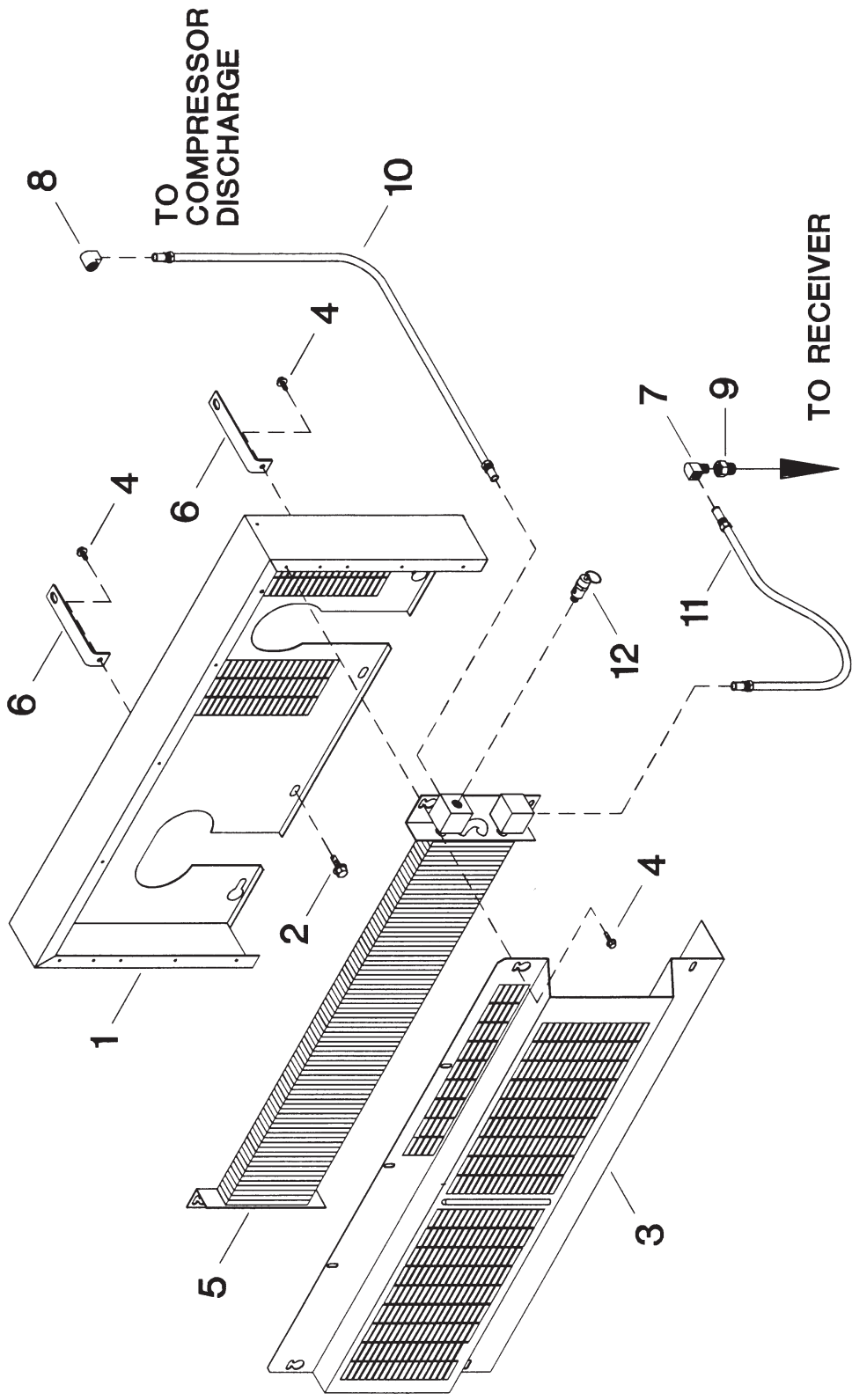

BELTGUARD & AIR COOLED AFTERCOOLER

REF. NO.	PART NUMBER (QTY.)			DESCRIPTION
	2340X2	2340D2	2340N2	2-2340D2
	H2340X2	2340D3	2340N3	2-2340D3
	2340X3	H2340D3		
	H2340X3			
10-1	32281040 (1)	32281040 (1)	32281040 (2)	BACK, BELTGUARD — SHEET METAL BELTGUARD
10-2	32000705 (4)	32000705 (4)	32000705 (8)	SCREW, TAPPING — 1/4 X 3/4"
10-3	32281073 (1)	32281073 (1)	32281073 (2)	COVER, ACAC
10-4	32187056 (14)	32187056 (14)	32187056 (28)	SCREW, SELF-DRILLING
10-5	32498149 (1)	32498149 (1)	32498149 (2)	COIL, ACAC
10-6	32295321 (2)	32295321 (2)	32295321 (4)	BRACE, BELTGUARD — SHEET METAL BELTGUARD
10-7	—	95083226 (1)	95083226 (2)	CONNECTOR — 5/8 X 1/2"
10-8	95031795 (1)	95031795 (2)	95031795 (1)	ELBOW, TUBE — 5/8 X 1/2"
10-9	—	97162812 (1)	97162812 (1)	VALVE, CHECK — 3/4 X 1/2"
10-10	32498206 (1)	32498206 (1)	32498206 (2)	TUBE, COMPRESSOR TO AFTERCOOLER
10-11	—	32498214 (1)	32498222 (1)	TUBE, AFTERCOOLER TO RECEIVER
10-12	32174286 (1)	32174286 (1)	32174286 (1)	VALVE, SAFETY/RELIEF
NI	—	95006540 (1)	—	TEE, PIPE — 1/2"
NI	—	95033593 (1)	95033593 (2)	PLUG, PIPE — 1/4"
NI	—	—	32186421 (2)	BUSHING, REDUCING — 1 X 3/4"
NI	—	—	95006565 (1)	TEE, PIPE — 1"
NI	—	—	95408787 (1)	NIPPLE, LONG — 1 X 3-1/2"
NI	—	—	32131724 (2)	COUPLING, PIPE — 1"

The automatic drain valve removes condensed water and oil from compressed air systems without restricting air flow, creating pressure drops or opening the system to the atmosphere. Its unique design maintains systems pressure and volume during operation, and increases productivity.

REF. NO.	PART NUMBER	DESCRIPTION
REF.	32296238	VALVE, AUTOMATIC DRAIN (SIMPLEX UNITS)
REF.	32310690	VALVE, AUTOMATIC DRAIN (DUPLIX UNITS)
11-1	32310971	KIT, WATER CAP ASSEMBLY
11-2	32314924	KIT, BODY/PISTON ASSEMBLY (FOR 32296238 VALVE)
11-2	32296246	KIT, BODY/PISTON ASSEMBLY (FOR 32310690 VALVE)
11-3	32310997	KIT, ONE WAY VALVE
11-4	32496317	RESERVOIR, STANDARD CAPACITY
11-4	32496309	RESERVOIR, HIGH CAPACITY
11-5	32311060	ELBOW, TUBE — 1/4"

* The high capacity reservoir gives the automatic drain valve twice as much condensate storage capacity during the pumping cycle. This larger reservoir is available as an upgrade. A larger reservoir is recommended for use on heavily-loaded simplex compressors with long pumping cycles and/or operating in extremely humid environments. If the pumping cycle exceeds one hour, then an electric timer kit should be used.

AUTOMATIC DRAIN VALVE TIMER KITS

An automatic drain valve timer kit resolves application problems in which an existing automatic drain valve cycles too infrequently. A timer generates the pneumatic signals for actuating the automatic drain valve. With a timer, the automatic drain valve operates independently of the compressor unload cycles.

PART NUMBER	DESCRIPTION
32499964	KIT, ELECTRIC TIMER - AUTOMATIC DRAIN VALVE

FIGURE 11. AUTOMATIC DRAIN VALVE REPLACEMENT PARTS.

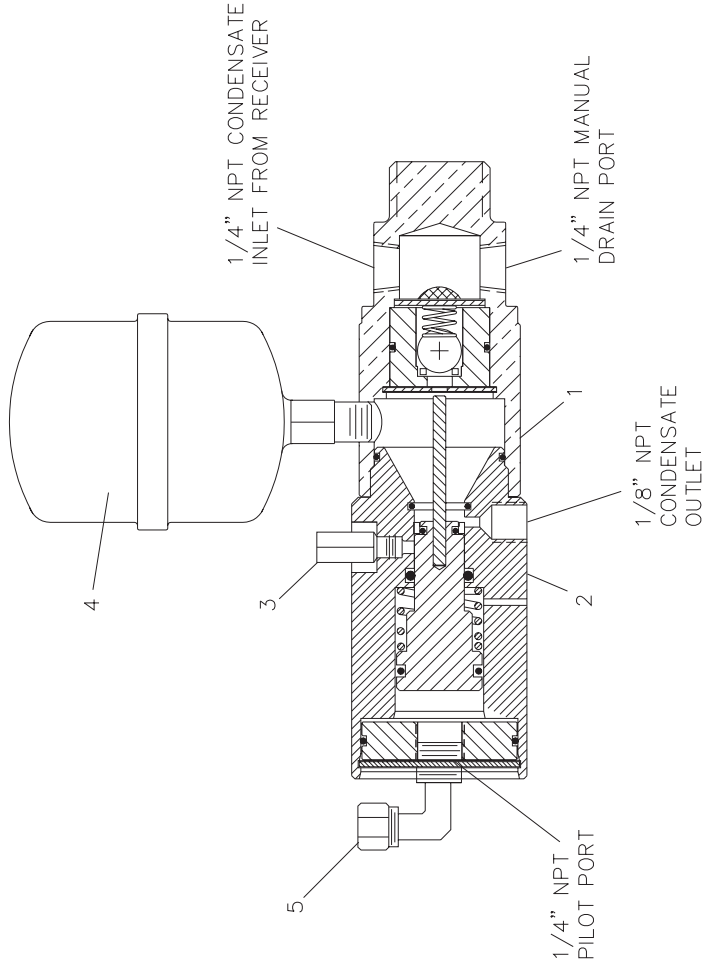

MAINTENANCE PAKS

Maintenance paks contain all the parts necessary for one complete routine maintenance service of your compressor. All-Season T30 Select lubricant, air filter elements, gaskets, drive belts, and instructions are standard with all maintenance paks.

PART NUMBER	MODEL
38485132	2340L5

VIBRATION ISOLATOR PADS

Vibration isolator pads are designed to absorb 40%-60% of the sound and vibration of your compressor.

PART NUMBER	DESCRIPTION
32320681	PAD, VIBRATION ISOLATOR - 4" X 4" SP-NR
32320699	PAD, VIBRATION ISOLATOR - 5" X 5" SP-NR
32321002	PAD, VIBRATION ISOLATOR - 4" X 4" NRC
32321028	PAD, VIBRATION ISOLATOR - 5" X 5" NRC
32321010	PAD, VIBRATION ISOLATOR - 6" X 6" NRC

SP-NR: Steel plate bonded between a NR pad and a non-skid oil-resistant ribbed neoprene top pad.

NRC: Two ribbed neoprene pads bonded to ½" cork pad.

COMPRESSOR LUBRICANT

All Season T30 Select® is an all-temperature diester synthetic lubricant that is formulated for exceptional lubrication at low, normal and high operating temperatures.

PART NUMBER	DESCRIPTION
32318875	LUBRICANT, ALL SEASON T30 SELECT - QUART
32318883	LUBRICANT, ALL SEASON T30 SELECT - CASE OF 12 QUARTS

CRANKCASE HEATER KITS

Crankcase heaters are recommended when ambient temperatures are consistently below 32°F (0°C). An easy-to-install external crankcase heater kit is intended for aftermarket use. Two kits may be required for some applications.

PART NUMBER	DESCRIPTION
97330385	KIT, CRANKCASE HEATER

START-UP KITS

Each start-up kit contains the necessary quantities of All Season T30 Select lubricant and air filter element(s) to start-up and maintain your compressor for the first year. Start-Up kits for gasoline engine driven models also include a replacement engine air filter, engine oil filter, and engine lubricant. See the engine manufacturer's instructions for more detailed engine care information.

PART NUMBER	DESCRIPTION
32305880	KIT, START-UP — 2340

STEP SAVER KITS

Step Saver Kits provide all of the parts required to perform common repair or scheduled maintenance tasks, such as piston ring replacement or valve replacement.

PART NUMBER	DESCRIPTION	CONTENTS
32304610	KIT, VALVE/GASKET	Valve wearing parts and head gaskets that are destroyed in replacing valve parts.
32304602	KIT, RING/GASKET	Complete set of piston rings, a crankshaft seal, and gaskets that are destroyed in breaking the unit down to replace the rings.
32127359	KIT, BEARING/CONNECTING ROD SET, GASKET	Set of connecting rods, main bearings, and a crankpin bushing, a gasket set is recommended with this kit.
		Complete set of gaskets that are destroyed in breaking the unit down for service. Recommended with bearing/connecting rod kit or as spare gaskets.
32319451	KIT, OVERHAUL	All of the above for complete overhaul service.

LOOK WHAT INGERSOLL-RAND CAN DO FOR YOU!



Efficient Field Service

We maintain a highly trained staff of technicians to service your equipment for preventive maintenance, or to assist you should emergencies ever occur.



Complete Repair Service

Our trained technicians will repair or overhaul your equipment to factory specifications, using only genuine I-R parts.



Special Engineering Service

We can help you identify and solve your problems by evaluating your needs and recommending the proper equipment to give you maximum efficiency.



Spare Parts

By stocking genuine I-R spare parts, we can help you avoid costly delays or substituting inferior parts. Using genuine I-R parts on your I-R equipment will help to keep even older equipment running in good-as-new condition.



Complete Stock of Equipment

We carry a complete line of I-R equipment and accessories designed to meet any compressed air application. We are backed by I-R's prompt factory shipment to ensure you on-time delivery.

A SUBSTITUTE IS NOT A REPLACEMENT!

Ensure you get peak performance and longevity out of your Ingersoll-Rand product by insisting on genuine Ingersoll-Rand replacement parts and maintenance kits. Not only are the replacement parts made to precise dimensions and OEM-specified metallurgy, but each part is backed by the Ingersoll-Rand warranty. Your local Air Center, Distributor, or direct Ingersoll-Rand salesperson will work with you to ensure you get the parts you need to do the job right. Equip your machines with only the best — Ingersoll-Rand genuine parts.

NOTE: THE USE OF REPAIR PARTS OTHER THAN THOSE INCLUDED WITHIN THE INGERSOLL-RAND COMPANY APPROVED PARTS LIST MAY CREATE UNSAFE CONDITIONS OR MECHANICAL FAILURES OVER WHICH INGERSOLL-RAND COMPANY HAS NO CONTROL. INGERSOLL-RAND COMPANY SHALL BEAR NO RESPONSIBILITY FOR EQUIPMENT ON WHICH NON-APPROVED REPAIR PARTS ARE INSTALLED.

The manufacturer reserves the right to make changes or add improvements without notice and without incurring any obligation to make such changes to products previously sold.