



OPERATOR'S MANUAL

MODEL #73500i
PARALLEL OPERATION KIT



REGISTER YOUR PRODUCT ONLINE

at championpowerequipment.com



or visit championpowerequipment.com

READ AND SAVE THIS MANUAL. This manual contains important safety precautions which should be read and understood before operating the product. Failure to do so could result in serious injury. This manual should remain with the product.
Specifications, descriptions and illustrations in this manual are as accurate as known at the time of publication, but are subject to change without notice.
WARNING: Cancer and Reproductive Harm – www.P65Warnings.ca.gov

ASSEMBLY AND OPERATION

This kit is intended for use on Champion Power Equipment 2000 Watt Inverter Generators. Please refer to your Inverter Owner's Manual for safety rules, start up and shut down procedures, specifications and troubleshooting.

Setup and Operation

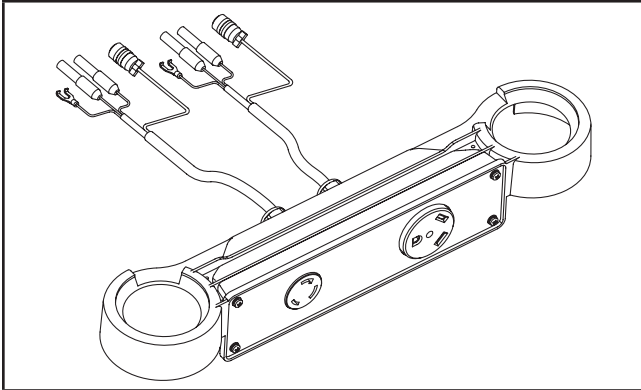

1. The two generators may be stacked one on top of the other by aligning the lower pads and upper pockets at each corner of the generators.

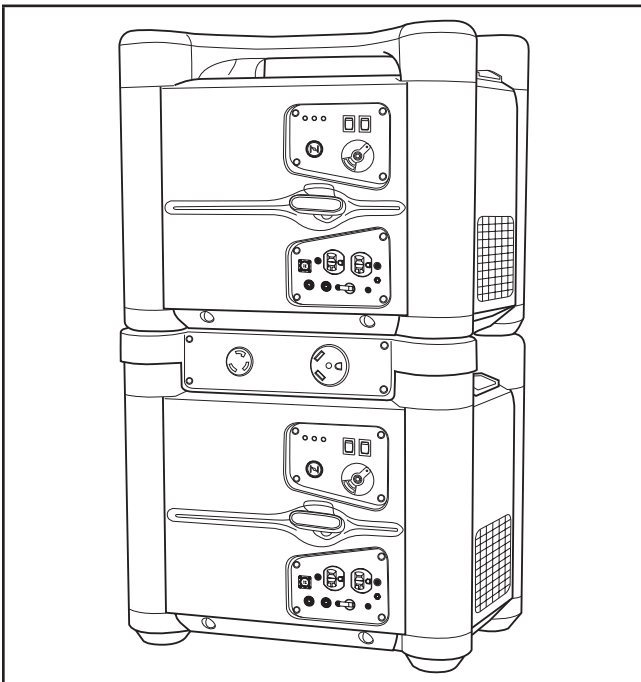

2. Disconnect or turn off all electrical loads from both generators.
3. The economy switch must be in the same position on both generators.
4. Remove caps from the power leads
5. Plug one pair of power leads (B), communication cable (A), and ground wire (C) to inverter #1.

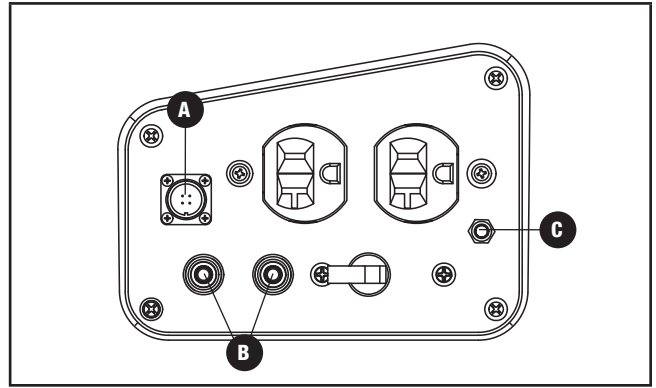

6. Plug the other pair of power leads (B), communication cable (A), and ground wire (C) to inverter #2.
7. Align pins of the communication cable when connecting (A).

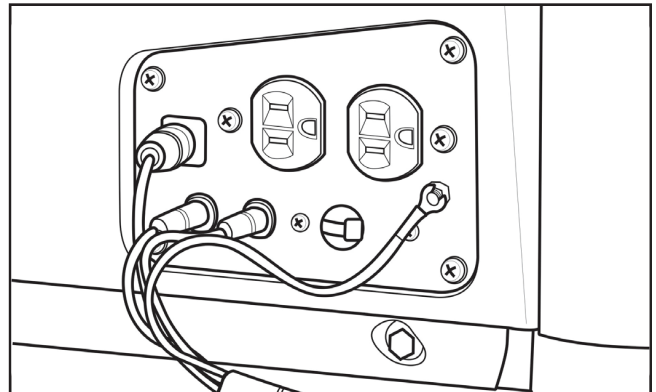

8. Start engines of both inverters according to your Inverter Operator's Manual. Observe the green output indicator light on both generator panels – The light will blink during start up. When the light is steady you may connect devices.
9. Connect devices to parallel panel or generator panel receptacles. Loads up to 25 amps may be connected to the parallel kit receptacles. Individual loads connected to generator panels must be less than the 20 amp panel receptacle rating.
10. The total electrical load must not exceed 30 amps (3600 watts).
11. Follow the instructions in your Inverter Owner's Manual for turning off the generators.
12. Pull "sleeve" of communication cable to disconnect.

Parts Diagram

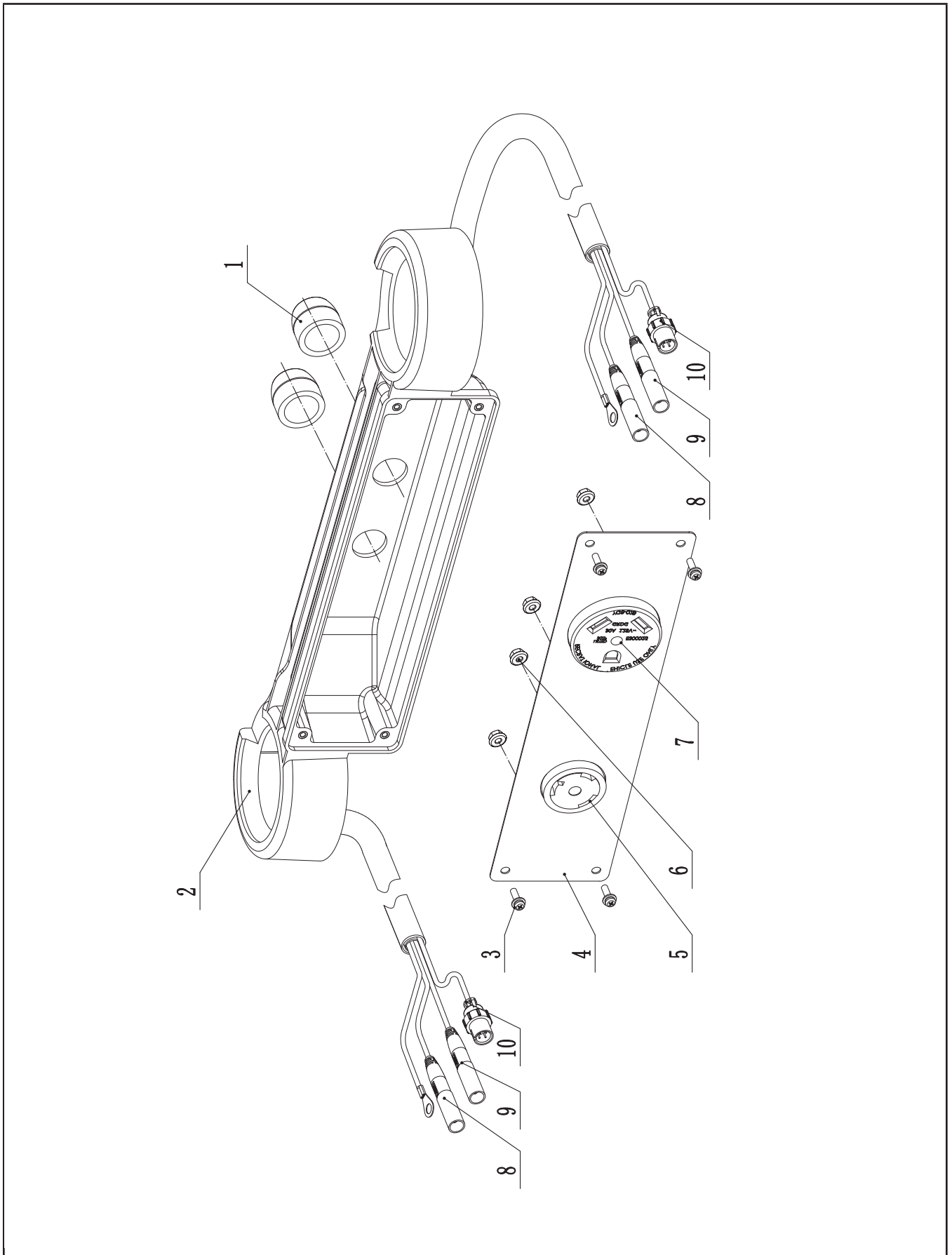

Parts List

#	Part Number	Description	Qty.
1	81.210003.00	Plug, Wire	2
2	81.213001.01	Control Box	1
3	1.9074.4.0414.1	Screw/Washer Assembly M4×14, Black	4
4	81.213100.00.2	Control Panel	1
5	5.1120.023	Receptacle L5-30R, CSA	1
6	1.6177.1.04.1	Lock Nut M4, Flange, Black	4
7	5.1120.034	Receptacle TT-30R	1
8	5.1900.053	Plug, Parallel, Wire 250 mm, Black	2
9	5.1900.054	Plug, Parallel, Wire 280 mm, Black	2
10	5.1130.000	Receptacle	2

Wiring Diagram

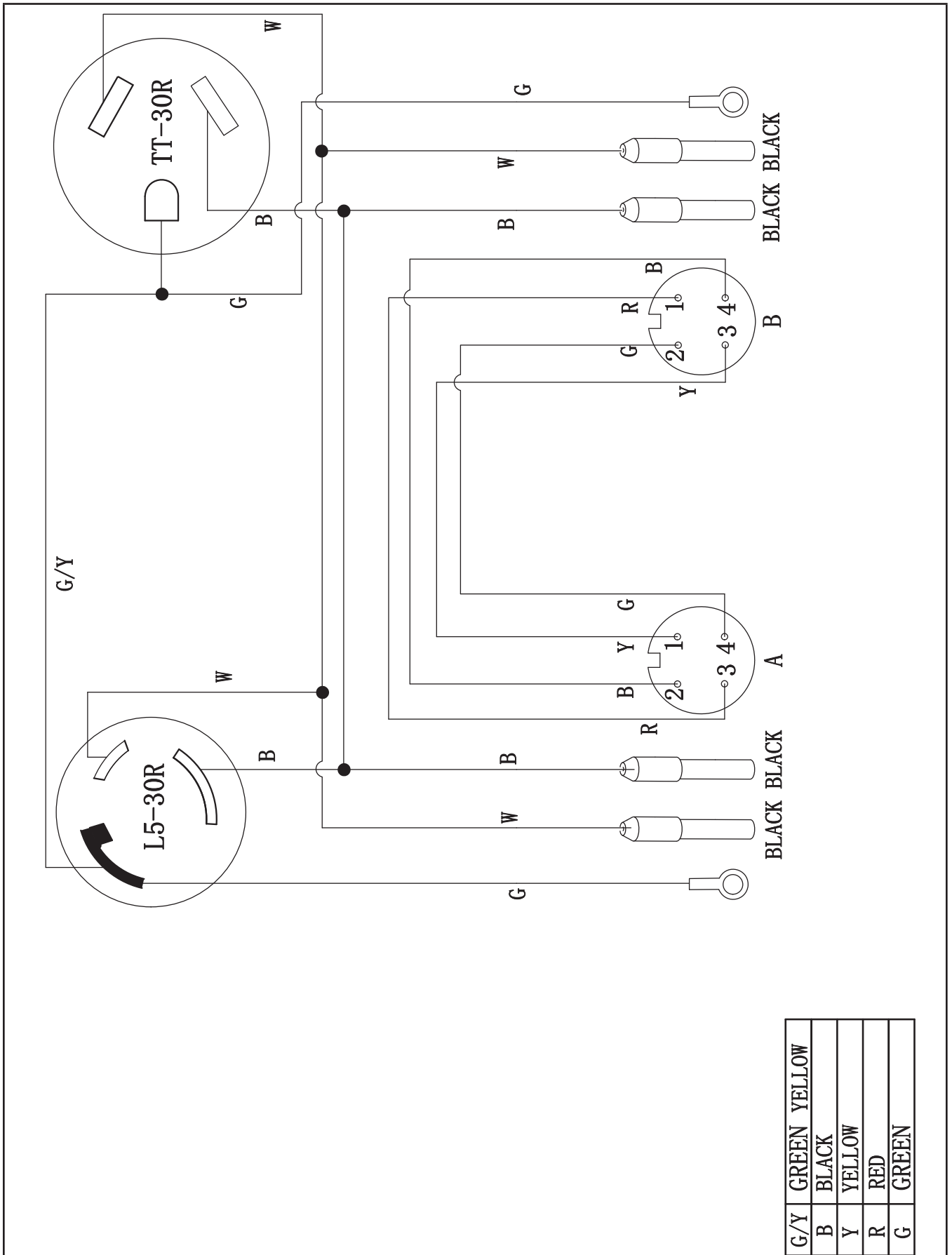

WARRANTY*

CHAMPION POWER EQUIPMENT
1 YEAR LIMITED WARRANTY

Warranty Qualifications

To register your product for warranty and FREE lifetime call center technical support please visit:

<https://www.championpowerequipment.com/register>

To complete registration you will need to include a copy of the purchase receipt as proof of original purchase. Proof of purchase is required for warranty service. Please register within ten (10) days from date of purchase.

Repair/Replacement Warranty

CPE warrants to the original purchaser that the mechanical and electrical components will be free of defects in material and workmanship for a period of one year (parts and labor) from the original date of purchase and 90 days (parts and labor) for commercial and industrial use. Transportation charges on product submitted for repair or replacement under this warranty are the sole responsibility of the purchaser. This warranty only applies to the original purchaser and is not transferable.

Do Not Return The Unit To The Place Of Purchase

Contact CPE's Technical Service and CPE will troubleshoot any issue via phone or e-mail. If the problem is not corrected by this method, CPE will, at its option, authorize evaluation, repair or replacement of the defective part or component at a CPE Service Center. CPE will provide you with a case number for warranty service. Please keep it for future reference. Repairs or replacements without prior authorization, or at an unauthorized repair facility, will not be covered by this warranty.

Warranty Exclusions

This warranty does not cover the following repairs and equipment:

Normal Wear

Products with mechanical and electrical components need periodic parts and service to perform well. This warranty does not cover repair when normal use has exhausted the life of a part or the equipment as a whole.

Installation, Use and Maintenance

This warranty will not apply to parts and/or labor if the product is deemed to have been misused, neglected, involved in an accident, abused, loaded beyond the product's limits, modified, installed improperly or connected incorrectly to any electrical component. Normal maintenance is not covered by this warranty and is not required to be performed at a facility or by a person authorized by CPE.

Other Exclusions

This warranty excludes:

- Cosmetic defects such as paint, decals, etc.
- Wear items such as filter elements, o-rings, etc.
- Accessory parts such as starting batteries, and storage covers.
- Failures due to acts of God and other force majeure events beyond the manufacturer's control.
- Problems caused by parts that are not original Champion Power Equipment parts.

Limits of Implied Warranty and Consequential Damage

Champion Power Equipment disclaims any obligation to cover any loss of time, use of this product, freight, or any incidental or consequential claim by anyone from using this product. THIS WARRANTY IS IN LIEU OF ALL OTHER WARRANTIES, EXPRESS OR IMPLIED, INCLUDING WARRANTIES OF MERCHANTABILITY OR FITNESS FOR A PARTICULAR PURPOSE.

A unit provided as an exchange will be subject to the warranty of the original unit. The length of the warranty governing the exchanged unit will remain calculated by reference to the purchase date of the original unit.

This warranty gives you certain legal rights which may change from state to state or province to province. Your state or province may also have other rights you may be entitled to that are not listed within this warranty.

Contact Information

Address

Champion Power Equipment, Inc.
12039 Smith Ave.
Santa Fe Springs, CA 90670 USA
www.championpowerequipment.com

Customer Service

Mon – Fri 8:30 AM – 5:00 PM (PST/PDT)
Toll Free: 1-877-338-0999
info@championpowerequipment.com
Fax no.: 1-562-236-9429

Technical Service

Mon – Fri 8:30 AM – 5:00 PM (PST/PDT)
Toll Free: 1-877-338-0999
tech@championpowerequipment.com
24/7 Tech Support: 1-562-204-1188