

Owner's Instruction and Operation Manual



Model Number:

6041i



Report Number: F20-573

Tested Per EPA Method ASTM E2779-10
and ASTM E1509-2022

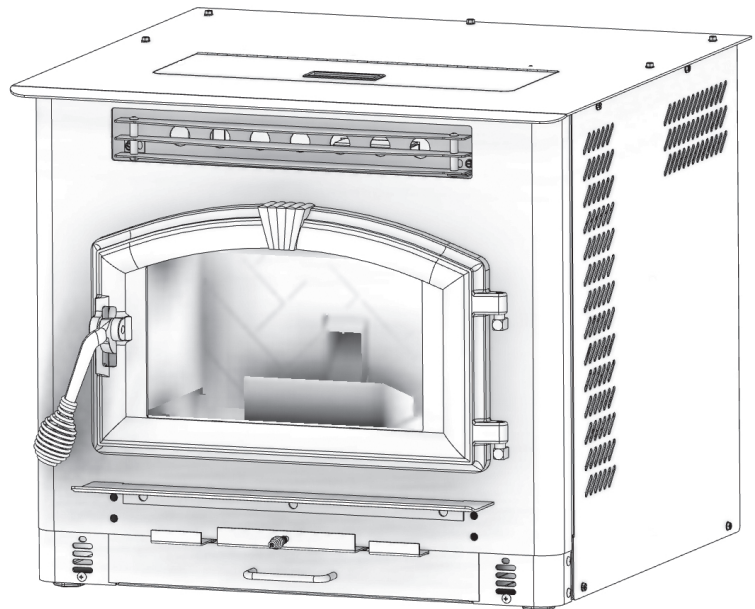

* All Pictures In This Manual Are For Illustrative Purposes Only. Actual Product May Vary.

851772L-2104M

Save These Instructions In A Safe Place For Future Reference.



SAFETY NOTICE: If this heater is not properly installed, a house fire may result. For your safety, follow the installation instructions. Never use make-shift compromises during the installation of this heater. Contact local building or fire officials about permits, restrictions and installation requirements in your area. **NEVER OPERATE THIS PRODUCT WHILE UNATTENDED.**



CAUTION! Please read this entire manual before you install or use your new room heater. Failure to follow instructions may result in property damage, bodily injury, or even death. Improper Installation Will Void Your Warranty!

U.S. Environmental Protection Agency

Certified to comply with 2020 particulate emissions standards.



CALIFORNIA PROPOSITION 65 WARNING:

This product can expose you to chemicals including carbon monoxide, which is known to the State of California to cause cancer, birth defects, and/or other reproductive harm. For more information, go to www.P65warnings.ca.gov

THIS MANUAL IS SUBJECT TO CHANGE WITHOUT NOTICE.

This manual describes the installation and operation of the USSC 60411 wood heater. This heater meets the 2020 U.S. Environmental Protection Agency’s crib wood emission limits for wood heaters sold after May 15, 2020. Under specific test conditions this heater has been shown to deliver heat at rates ranging from 7,540 to 21,811 Btu/hr output. This heater achieved a particulate emissions rate of 1.3 g/hr and 58% efficiency when tested to method ASTM E 2779-10.

Heating Specifications		
Heating Capacity	1,000-2,000 Sq. Ft	* Pellet size may effect the actual rate of fuel feed and burn times. Fuel feed rates may vary by as much as 20%. Use PFI listed fuel for best results.
Fuel Storage Capacity	60 Lbs.	
Flue Size	3" or 4"	
Electrical Specifications		
Electrical Rating	120 Volts, 60 HZ, 15 Amps	
Dimensions		
Overall: Height x Width X Depth	29" X 24" X 28" (737 mm X 610 mm X 711 mm)	

WARNING:

IT IS AGAINST FEDERAL REGULATIONS TO OPERATE THIS WOOD HEATER IN A MANNER INCONSISTENT WITH THE OPERATING INSTRUCTIONS IN THE OWNER’S MANUAL.



Note: Register your product online at www.usstove.com or download the free app today. This app is available only on the App Store for iPhone and iPad. Search US Stove. Save your receipt with your records for any claims.

For Customer Service, please call:
1-800-750-2723 Ext 5050 or;
Text to 423-301-5624 or;
Email us at:
customerservice@usstove.com

INSTALLATION CHECKLIST



Your Wood Stove should be installed by a qualified installer only. An NFI qualified Installer can be found at www.nficertified.org/public/find-an-nfi-pro/

CUSTOMER SERVICE

1-800-750-2723 ext 5050
Text to 423-301-5624
Email to: Customerservice@usstove.com

COMMISSIONING CHECKLIST

This checklist is to be completed in full by the qualified person who installs this unit. Keep this page for future reference. Failure to install and commission according to the manufacturer's instructions and complete this checklist will invalidate the warranty.

Please Print

Customer Name:	Telephone Number:
Address:	
Model:	
Serial Number:	
Installation Company Name:	Phone Number:
Installation Technician's Name:	License Number:

DESCRIPTION OF WORK

Location of installed appliance: _____

Venting System: New Venting System Yes No If yes, Brand _____

If no, Date of inspection of existing venting system: _____

COMMISSIONING

- Confirm Hearth Pad Installation as per Installation Instructions.....
- Confirm proper placement of internal parts.....
- Check soundness of door gasket and door seals
- Confirm clearances to combustibles as per installation instructions in this manual
- Check the operations of the air controls.....
- Confirm the venting system is secure and sealed
- Confirm the stove starts and operates properly
- Check to ensure a CO alarm is installed as per local building codes and is functional
- Explain the safe operation, proper fuel usage, cleaning, and routine maintenance requirements.....

Declaration of Completion: As the qualified person responsible for the work described above, I confirm that the appliance as associated work has been installed as per manufacturer's instructions and following any applicable building and installation codes.

Signed: _____ Print Name: _____ Date: _____

Home Owner: RETAIN THIS INFORMATION FOR FUTURE REFERENCE

CAUTION:

**DISCONNECT THE POWER CORD BEFORE
SERVICING THIS HEATER**

For the following assemblies, we suggest locating the unit near it's desired location. Depending on installation, you may want to connect the exhaust venting before installing the facade parts.

ASSEMBLY - FACADE (SURROUND)

Remove contents from packaging and make sure you have all components:

- (2) Top Facade (a)
- (1) Left Side Facade (b)
- (1) Right Side Facade (c)
- (4 pieces) Facade Trim Kit (d)
- (1) Feed Door Spring Handle (e)
- (1) Damper Spring Handle (f)
- (1) Ash Pan "U" shaped Handle (g)
- (1) Access Door Knob (h)
- (1) PCB Cover (i)
- (1) Panel Cover (j)
- (1) Auger (in ash pan)
- (1) Power Cord
- (1) Burnpot Poker (k)

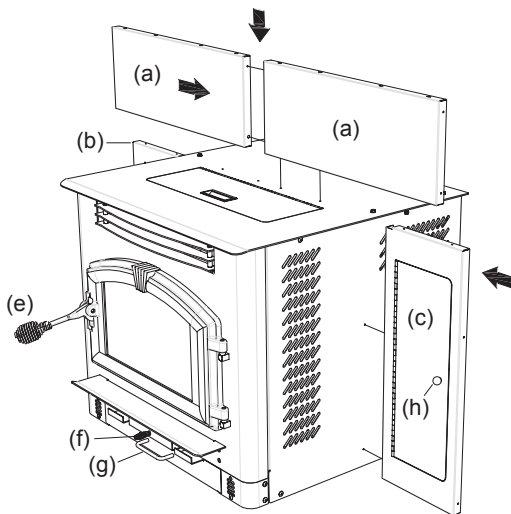

MOUNTING HARDWARE

Start by mounting either the left or right side facade pieces to the unit using four(4) of the supplied #10 x 1/2 screws. Then put the two(2) top facade pieces together

with two(2) of the #10 x 1/2 screws provided. Attach the top facade assembly to the unit with eight(8) of the same screws.

CONTROL BOARD (PCB) RE-LOCATION

Remove the left side front panel from the unit. While holding the PCB with one hand, remove the two(2) hex head screws holding the board in place. It is not necessary to unplug the PCB cable. Route the board and cable through the opening and mount it to the Left Facade using two of the #10 x 1/2 phillips head screws provided. Then attach the PCB cover to the back of the facade covering the board. Next, use the two hex head screws removed earlier and mount the cover panel over the opening where the PCB was located. See illustration to the left.

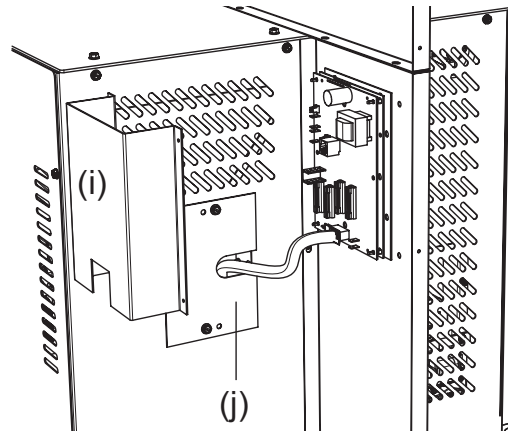

FACADE TRIM

Remove trim from shipping tube. There should be one(1) left side, one(1) right side, two(2) top pieces, and mounting hardware. Using one blank corner key and one corner key with set screws, assemble the left trim and one of the top pieces together. As illustrated, place the blank key behind the key with the set screws. Adjust corners and tighten set screws. Repeat this for the right side. Before removing tape, place trim assembly against facade to get an idea of how it is to be mounted. Remove the strip from the adhesive and carefully secure the trim in place by firmly pressing it to the facade.

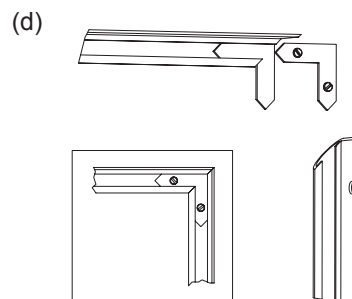

BURNPOT POKER

The burnpot poker may be used several ways. It is used primarily as a fuel-loading assistant to help push the fuel to the rear of the hopper for maximum fueling. It may also be used for cleaning of ashes or removal of clinkers.

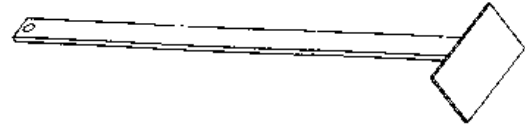

INSTALLATION

FOR CUSTOMER SERVICE CALL: 800-750-2723 EXT 5050

SAFETY NOTICE

- **IF THIS STOVE IS NOT PROPERLY INSTALLED, A HOUSE FIRE MAY RESULT. TO REDUCE THE RISK OF FIRE, FOLLOW THE INSTALLATION INSTRUCTIONS.**
- **CONTACT YOUR LOCAL BUILDING OFFICIALS TO OBTAIN A PERMIT AND INFORMATION ON ANY ADDITIONAL INSTALLATION RESTRICTIONS OR INSPECTION REQUIREMENTS IN YOUR AREA.**
- **DO NOT PLACE CLOTHING OR OTHER FLAMMABLE ITEMS ON OR NEAR THIS STOVE.**
- **NEVER USE GASOLINE, GASOLINE-TYPE LANTERN FUEL, KEROSENE, CHARCOAL LIGHTER FLUID, OR SIMILAR LIQUIDS TO START OR 'FRESHEN UP' A FIRE IN THIS STOVE. KEEP ALL SUCH LIQUIDS WELL AWAY FROM THE STOVE WHILE IT IS IN USE.**
- **DO NOT CONNECT THIS HEATER TO "B" VENT. USE UL LISTED PELL VENT ONLY!**
- **DO NOT ELEVATE THE FIRE BY USE OF GRATE OR ANY OTHER MEANS OTHER THAN THE SUPPLIED BURNPOT.**
- **YOUR STOVE REQUIRES PERIODIC MAINTENANCE AND CLEANING (SEE "MAINTENANCE"). FAILURE TO MAINTAIN YOUR STOVE MAY LEAD TO IMPROPER AND/OR UNSAFE OPERATION.**
- **ALWAYS ROUTE THE POWER CORD AWAY FROM THE UNIT. DO NOT ROUTE CORD IN FOOT TRAFFIC AREAS. DO NOT PINCH CORD UNDER FURNITURE. DO NOT ROUTE THE CORD ACROSS THE EXHAUST PIPE.**
- **A POWER SURGE PROTECTOR IS REQUIRED. THE UNIT MUST BE PLUGGED INTO A GROUNDED 110-VOLT POWER SOURCE.**

CAUTION:

BURNING FUEL CREATES CARBON MONOXIDE AND CAN BE HAZARDOUS TO YOUR HEALTH IF NOT PROPERLY VENTED.

ATTENTION:

- **A WORKING SMOKE DETECTOR MUST BE INSTALLED IN THE SAME ROOM AS THIS PRODUCT.**
- **INSTALL A SMOKE DETECTOR ON EACH FLOOR OF YOUR HOME; IN CASE OF ACCIDENTAL FIRE FROM ANY CAUSE IT CAN PROVIDE TIME FOR ESCAPE.**
- **THIS HEATER IS NOT INTENDED FOR USE IN COMMERCIAL INSTALLATIONS.**
- **THIS PRODUCT REQUIRES SIMPLE PERIODIC MAINTENANCE FOR PROPER OPERATION AND LONG LIFE OF THE HEATER. READ AND FOLLOW THE MAINTENANCE SCHEDULE CLOSELY.**

CAUTION:

- **DO NOT UNPLUG THE STOVE IF YOU SUSPECT A MALFUNCTION. TURN THE ON/OFF SWITCH TO "OFF" AND CONTACT YOUR DEALER.**
- **THE HEATER WILL NOT OPERATE DURING A POWER OUTAGE. IF A POWER OUTAGE DOES OCCUR, CHECK THE HEATER FOR SMOKE SPILLAGE AND OPEN A WINDOW IF ANY SMOKE SPILLS INTO THE ROOM.**

NATIONAL FIREPLACE INSTITUTE
NFI
CERTIFIED
www.nficertified.org

We recommend that our woodburning hearth products be installed and serviced by professionals who are certified in the U.S. by the National Fireplace Institute® (NFI) as NFI Woodburning Specialists or who are certified in Canada by Wood Energy Technical Training (WETT).

Wood Energy Technical Training
www.wettinc.ca

US Stove highly recommends your stove be installed by a qualified NFI (US) or WETT (Canada) technician. To find the nearest qualified installer, go to:

<https://nficertified.org>,

<https://www.wettinc.ca/>

INSTALLATION CONFIGURATIONS

This insert may be installed as follows:

1. In a pre-fab firebox (Factory Built)
2. In an existing masonry fireplace
3. As a build-in

FLOOR PROTECTION

This heater may be installed on a combustible floor, with proper floor protection, or on a masonry hearth. The hearth or noncombustible floor protector must extend a minimum of 6" (152mm) in front and 6" (152mm) from each side of the unit.

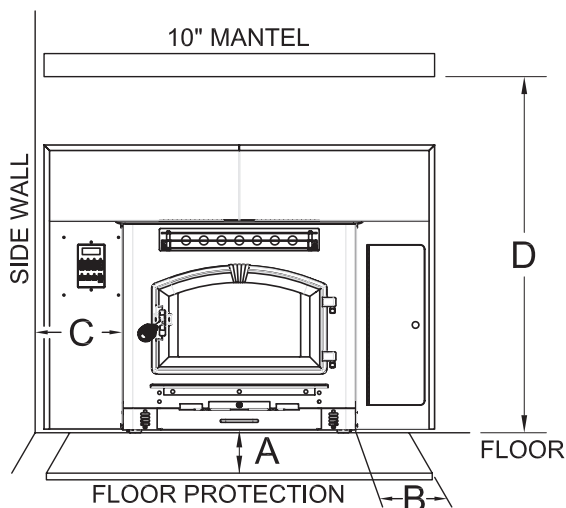

A	FLOOR PROTECTOR TO FRONT OF UNIT	6"
B	FLOOR PROTECTOR TO SIDE OF UNIT	6"
C	LEFT SIDE OF UNIT TO WALL	8"
D	FLOOR TO MANTEL	53"

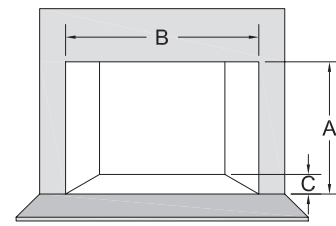

A	HEIGHT	24"
B	WIDTH	40"
C	DEPTH	20"

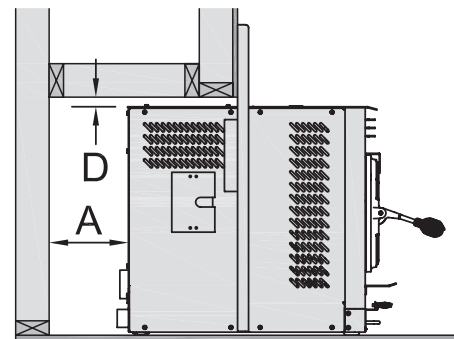
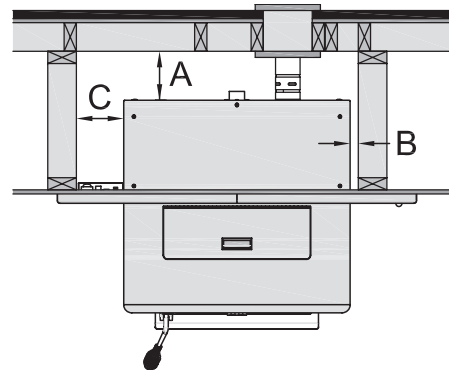

A	BACK OF UNIT TO WALL	6"
B	RIGHT SIDE OF UNIT TO WALL	1"
C	LEFT SIDE OF UNIT TO WALL	6"
D	TOP OF UNIT TO WALL	1"

OUTSIDE AIR SUPPLY (OPTIONAL, UNLESS INSTALLING IN A MOBILE HOME)

Depending on your location and home construction, outside air may be necessary for optimal performance. Your stove is approved to be installed with an outside air intake (69FAK) which is necessary for a mobile home. You can purchase the 69FAK through your heater dealer. Installation instructions are supplied with the air intake kit.

ATTENTION:

DO NOT VENT UNDER ANY PORCH, DECK, AWNING, OR IN ANY SEMI ENCLOSED OR ROOFED AREA. DOING SO MAY RESULT IN UNPREDICTABLE AIRFLOW AT THE VENT CAP UNDER CERTAIN CONDITIONS AND CAN AFFECT THE PERFORMANCE OF YOUR STOVE, AS WELL AS OTHER UNFORESEEABLE ISSUES.

WARNING! DO NOT INSTALL IN SLEEPING ROOM.

CAUTION! THE STRUCTURAL INTEGRITY OF THE MOBILE HOME FLOOR, WALL, AND CEILING/ROOF MUST BE MAINTAINED.

WHEN INSTALLED IN A MOBILE HOME, THE STOVE MUST BE GROUNDED DIRECTLY TO THE STEEL CHASSIS AND BOLTED TO THE FLOOR.

In addition to the previously detailed installation requirements, mobile home installations must meet the following requirements:

- This stove must be securely fastened to the floor of the mobile home using two 1/4" lag bolts that are long enough to go through both a hearth pad, if used, and the floor of the home.
- The heater must be electrically grounded to the steel chassis of the mobile home with 8 GA copper wire using a serrated or star washer to penetrate paint or protective coating to ensure grounding.
- Vent must be 3 or 4-inch "PL" Vent and must extend a minimum of 36" (914 mm) above the roof line of the mobile home and must be installed using a certified ceiling fire stop and rain cap.
- When moving your mobile home, all exterior venting must be removed while the mobile home is being relocated. After relocation, all venting must be reinstalled and securely fastened.
- Outside Air is mandatory for mobile home installation. See Outside Air Supply section and your dealer for purchasing.
- Check with your local building officials as other codes may apply.

INSTALL VENT AT CLEARANCES SPECIFIED BY THE VENT MANUFACTURER.

- A UL listed 3" or 4" type "PL" pellet vent exhaust system must be used for installation and attached to the pipe connector provided on the back of the heater.

Use a 3" to 4" adapter for 4" pipe. A 4" PL is required for elevations above 2,500 feet above sea level.

- Do not terminate vent in any enclosed or semi-enclosed area, such as; carports, garage, attic, crawl space, under a sundeck or porch, narrow walkway or close area, or any location that can build up a concentration of fumes such as a stairwell, covered breezeway etc.
- Vent surfaces can get hot enough to cause burns if touched by children. Noncombustible shielding or guards may be required.
- Do not install a flue damper in the exhaust vent of this unit.
- Termination must exhaust above air inlet elevation. Installation MUST include three (3) vertical feet of pellet vent pipe. This will create some natural draft to prevent the possibility of smoke or odor during appliance shutdown and to keep exhaust from causing a nuisance or hazard from exposing people or shrubs to high temperatures. Do not connect this unit to a chimney flue serving another appliance. Do not connect directly to a masonry chimney.
- The installation must include a cleanout tee to enable collection of fly ash and to permit periodic cleaning of the exhaust system. 90° elbows accumulate fly ash and soot thereby reducing exhaust flow and performance of the heater. Each elbow or tee reduces draft potential by 30% to 50%. Use no more than 180 degrees of elbows (two 90° elbows, or two 45° and one 90° elbow, etc.) and one cleanout tee to maintain adequate draft. Cleanout tees and elbows should not be connected to the rear of the unit unless a 3-inch adapter is used.
- Total length of horizontal vent must not exceed 48" (4ft.)/1,200mm. The maximum recommended vertical venting height is 12-feet for 3-inch type "PL" vent. For venting higher than 12-feet, 4-inch "PL" vent must be used. All joints in the vent system must be fastened by at least 3 screws, and all joints must be sealed with RTV silicone sealer to be airtight.
- The area where the vent pipe penetrates to the exterior of the home must be sealed with silicone or other means to maintain the vapor barrier between the exterior and the interior of the home.

NOTE: These are guidelines only. Proper venting is accomplished by design and necessary requirements. In most installations 3 inch diameter venting is adequate. If it does not vent properly you will have to change it to 4 inches. You should not exceed 4 inch diameter venting.

DO NOT CONNECT TO ANY AIR DISTRIBUTION DUCT OR SYSTEM

IMPORTANCE OF PROPER DRAFT

Draft is the force which moves air from the appliance up through the chimney. The amount of draft in your chimney depends on the length of the chimney, local geography, nearby obstructions and other factors. Too much draft may cause excessive temperatures in the appliance. Inadequate draft may cause backpuffing into the room and ‘plugging’ of the chimney. Inadequate draft will cause the appliance to leak smoke into the room through appliance and chimney connector joints. An uncontrollable burn or excessive temperature indicates excessive draft. Take into account the chimney’s location to ensure it is not too close to neighbors or in a valley which may cause unhealthy or nuisance conditions. It is recommended that only an authorized installer install your heater, preferably an NFI certified specialist. The following installation guidelines must be followed to ensure conformity with both the safety listing of this heater and to local building codes.

VENT TERMINATION CLEARANCES

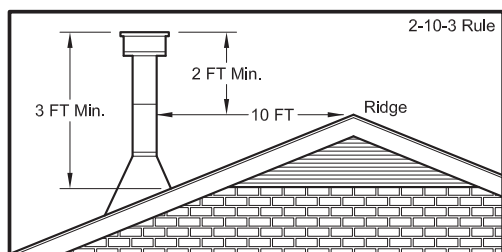
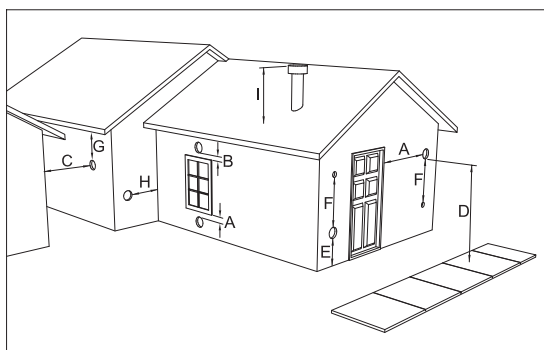

- D. Min. 4-ft clearance below or beside any door or window that opens.
- E. Min. 1-ft clearance above any door or window that opens.
- F. Min. 3-ft clearance from any adjacent building.
- G. Min. 7-ft clearance from any grade when adjacent to public walkways.
- H. Min. 2-ft clearance above any grass, plants, or other combustible materials.

- I. Min. 3-ft clearance from a forced air intake of any appliance.
- J. Min. 2-ft clearance below eaves or overhang.
- K. Min. 1-ft clearance horizontally from combustible wall.
- L. Must be a minimum of 36-inches above the roof and 24-inches above the highest point or the roof within 10-feet.

INSTALLATION AS A BUILT-IN FIREPLACE

A continuous sheet of non-combustible floor protection must be installed underneath the unit to prevent the possibility of embers falling through to the combustible floor. If the floor beneath the unit is of non-combustible material, the protector is not required. See the “Clearance to Combustibles” section of this manual for installation clearances.

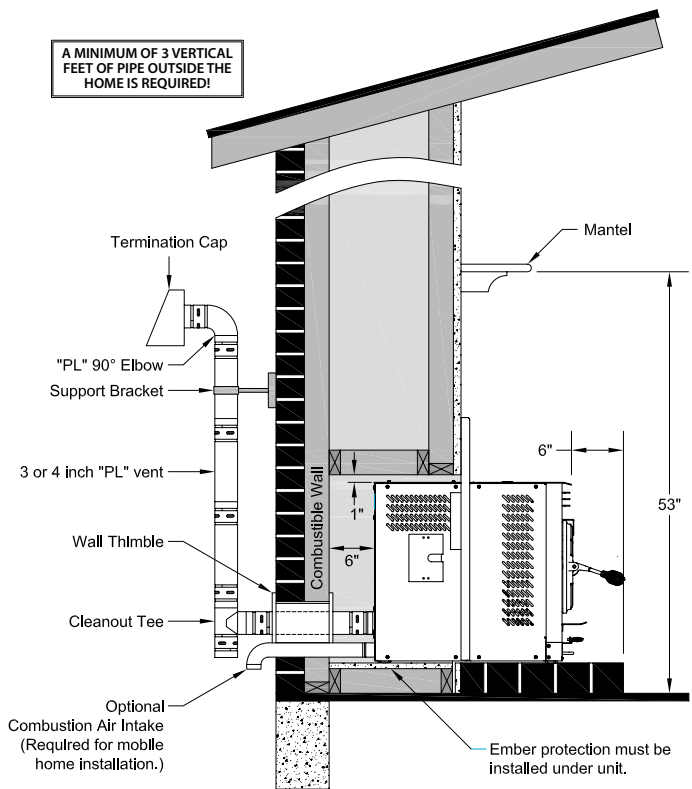

ALTERNATIVE EXHAUST VENTING

Depending on your installation, you might consider routing your cleanout tee as illustrated below for ease of cleaning. The access panel in the right side facade allows you to reach the tee from the front side of the unit if venting is assembled as shown. The cleanout tee is attached to a 90° elbow mounted to the unit then rotated at approx. 15-20 degrees. A 12 inch section of “PL” vent is connected to reach the top of the unit to which a flexible

pipe may be attached for further termination through a chimney. Clearance to combustibles must be considered if this installation is chosen. A distance of 3 inches must be maintained from the exhaust vent to any combustible material.

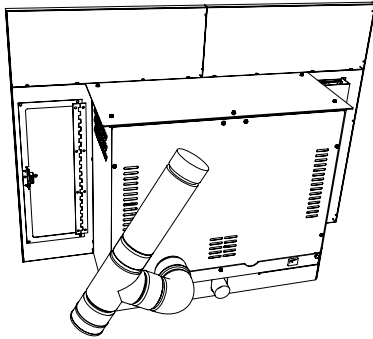

INSTALLATION INTO A MASONRY FIREPLACE

(4" Pell Vent "PL" Piping) that extends the full height of the chimney and meets type HT requirements. The liner must be securely attached to the insert and the chimney top. The chimney must be sealed either at the top or at the damper area with a non-combustible plate to prevent room air passage to chimney cavity. Outside combustion air may be drawn through the chimney top or through an existing ash cleanout.

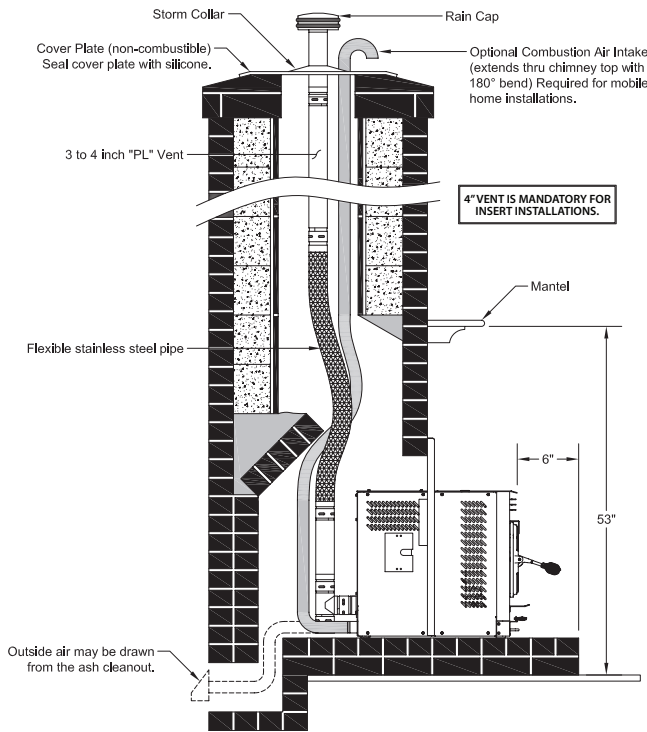

When installing into a masonry fireplace, DO NOT remove any bricks or masonry, with the following exception:

masonry or steel, including the damper plate, may be removed from the smoke shelf and adjacent damper frame, if necessary, to accommodate a chimney liner. Do this only if their removal will not weaken the structure of the fireplace or the chimney, and will not reduce protection for combustibles to less than that required by national building codes. Installation must include a chimney liner.

INSTALLATION INTO A FACTORY-BUILT (METAL) FIREPLACE

When installing into a zero clearance fireplace, The firebox must accept the insert without modification other than removing bolted or screwed together pieces such as smoke shelf/deflectors, ash lips, screen or door tracks, and damper assemblies. These items must be re-installed if the insert is removed and not replaced. The removal of any part must not alter the integrity of the listed fireplace in any way. The factory built fireplace must be listed per UL 127. Installation must include a chimney liner (4" Pell Vent "PL" Piping) that extends the full height of the chimney and meets type HT requirements. The liner must be securely attached to the insert and the chimney top. The chimney must be sealed either at the top or at the damper area with a non-combustible plate to prevent room air passage to chimney cavity. For raised hearth installations, adjust the leveling bolts under the front of the unit.

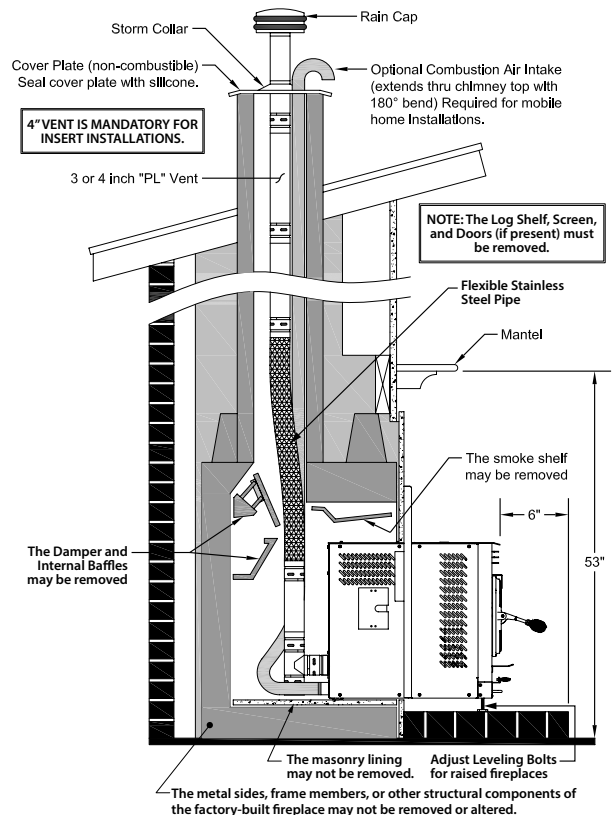

NEVER OPERATE THIS PRODUCT WHILE UNATTENDED

UNDERSTANDING THE CONTROL BOARD

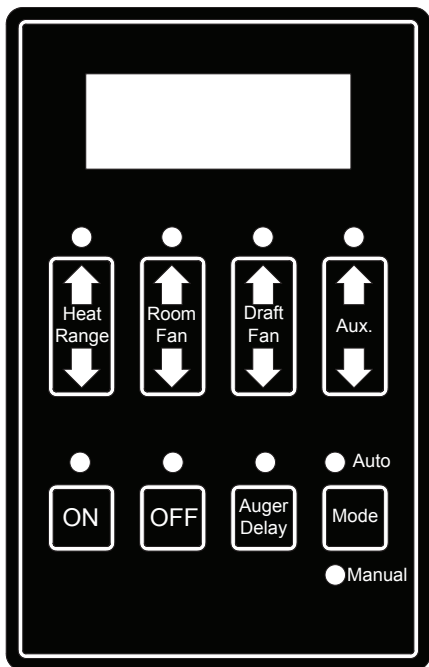

Turning the heater OFF/ON, as well as adjustments for the fuel feed rate and room fan speed are performed by pressing the appropriate button(s) on the control panel.

This unit has two fuel operation modes. It may also be changed between an automatic operation or a manual operation in either of the fuel modes.

- Pressing the “ON” button on the control panel will begin the start-up sequence for the heater. The start-up sequence differs depending on which fuel operation mode you select (see Lighting Instructions for details). Pressing and holding the “ON” button will rotate the auger continuously until the button is released, which feeds additional fuel.
- Pressing the “OFF” button on the control panel will cause the heater to enter its shut-down sequence. The fuel feed system will stop pulling fuel from the hopper and, once the fire goes out and the heater cools down, the fans will stop running.
- Pressing the “Heat Range” arrows, up or down, will adjust the amount of fuel being delivered to the burnpot.
- The draft fan (exhaust) will come on as soon as the “ON” button is pressed. The fan will automatically adjust its speed in accordance to the heat range setting. However, this speed can be manually operated by

pressing the “Draft Fan” arrows up or down. “Draft Fan” when pressed, the display will show “DF-A”, which is automatic. Press the arrows again to adjust fan speed. When adjusting the draft fan setting, try only

- One setting above or below the heat setting. It is better to leave the heater in the automatic mode and adjust the manual draft slide to control the combustion air.
- The room fan will come on once the unit has reached operating temperature (approx. 110°F). By pressing the “Room Fan” buttons, the display will show “RF-A” which is automatic or “RF-1” through “RF-9” for manual settings. In auto mode, the room fan’s speed will automatically be adjusted in accordance with the heat range setting. By pressing the “Room Fan” up arrow, you can adjust the fan speed setting up to “RF-9”. The fan speed can be adjusted to a higher setting than the heat setting but not lower than the corresponding heat range.
- The “Aux” button is for Agitator operation. When the unit is “OFF” and the heater is cool, pressing the “Aux” arrows will rotate the agitator for easy removal for cleaning. The agitator, when in Automatic mode, will operate at set intervals. However, these can be changed by pressing the arrows on the “Aux” button. The agitator can be adjusted from 0 to 9, setting “0” is off and setting “9” is high.
- The “Auger Delay” button can be used to pause rotation of the Auger and Agitator for approx. 1 minute. This can be cancelled by pressing the “ON” button. The “Auger Delay” is normally used only during the start up cycle to slow the fuel delivery down during the initial ignition.
- The “Mode” button is used to switch between manual and automatic mode. When in auto mode, the fan, auger, and agitator will operate at preset intervals unless changed manually using the buttons mentioned above. When in manual mode, the draft fan (exhaust) will operate at full speed (100%), so the air must be controlled with the manual slide damper just below the viewing door. When the heater is in the manual mode, the optional thermostat will not properly control the unit.
- During normal operation, the unit is constantly monitored for problems. In the event of an error condition, the unit will stop and an error will be displayed. See the list of error codes found at the end of this manual.

WARNING:

- **DO NOT USE CHEMICALS OR FLUIDS TO START THE FIRE - NEVER USE GASOLINE, GASOLINE-TYPE LANTERN FUEL, KEROSENE, CHARCOAL LIGHTER FLUID, OR SIMILAR LIQUIDS TO START OR “FRESHEN UP” A FIRE IN THIS STOVE. KEEP ALL SUCH LIQUIDS WELL AWAY FROM THE STOVE WHILE IT IS IN USE.**
- **HOT WHILE IN OPERATION. KEEP CHILDREN, CLOTHING AND FURNITURE AWAY. CONTACT MAY CAUSE SKIN BURNS.**

DO NOT BURN:

1. Garbage;
2. Lawn clippings or yard waste;
3. Materials containing rubber, including tires;
4. Materials containing plastic;
5. Waste petroleum products, paints or paint thinners, or asphalt products;
6. Materials containing asbestos;
7. Construction or demolition debris;
8. Railroad ties or pressure-treated wood;
9. Manure or animal remains;
10. Salt water driftwood or other previously salt water saturated materials;
11. Unseasoned wood; or
12. Paper products, cardboard, plywood, or particleboard. The prohibition against burning these materials does not prohibit the use of fire starters made from paper, cardboard, saw dust, wax and similar substances for the purpose of starting a fire in an affected wood heater.

Burning these materials may result in release of toxic fumes or render the heater ineffective and cause smoke.

PROPER FUEL

ATTENTION:

THIS APPLIANCE IS DESIGNED FOR THE USE OF PELLETIZED FUEL THAT MEET OR EXCEED THE STANDARD SET BY THE PELLET FUEL INSTITUTE (PFI).

Your pellet stove is designed to burn premium hardwood pellets that comply with the Pellet Fuels Institute (PFI) standard (minimum of 40 lbs density per cubic ft, 1/4” to 5/16” diameter, length no greater than 1.5”, not less than 8,200 BTU/lb, moisture under 8% by weight, ash under

1% by weight, and salt under 300 parts per million). Pellets that are soft, contain excessive amounts of loose sawdust, have been, or are wet, will result in reduced performance. Store your pellets in a dry place. DO NOT store the fuel within the installation clearances of the unit or within the space required for refuelling and ash removal. Doing so could result in a house fire. Do not over fire or use volatile fuels or combustibles, doing so may cause a personal and property damage hazards. THIS STOVE IS APPROVED FOR BURNING PELLETIZED WOOD FUEL ONLY ! Factory-approved pellets are those 1/4” or 5/16” in diameter and not over 1” long. Longer or thicker pellets sometimes bridge the auger flights, which prevents proper pellet feed. Burning wood in forms other than pellets is not permitted. It will violate the building codes for which the stove has been approved and will void all warranties. The design incorporates automatic feed of the pellet fuel into the fire at a carefully prescribed rate. Any additional fuel introduced by hand will not increase heat output but may seriously impair the stoves performance by generating considerable smoke. Do not burn wet pellets. The stove’s performance depends heavily on the quality of your pellet fuel. Avoid pellet brands that display these characteristics:

- Excess Fines – “Fines” is a term describing crushed pellets or loose material that looks like sawdust or sand. Pellets can be screened before being placed in hopper to remove most fines.
- Binders – Some pellets are produced with materials to hold the together, or “bind” them.
- High ash content – Poor quality pellets will often create smoke and dirty glass. They will create a need for more frequent maintenance. You will have to empty the burn pot plus vacuum the entire system more often. Poor quality pellets could damage the auger. We cannot accept responsibility for damage due to poor quality pellet.

CAUTION:

- **KEEP FOREIGN OBJECTS OUT OF THE HOPPER.**
- **THE MOVING PARTS OF THIS STOVE ARE PROPELLED BY HIGH TORQUE ELECTRIC MOTORS. KEEP ALL BODY PARTS AWAY FROM THE AUGER WHILE THE STOVE IS PLUGGED INTO AN ELECTRICAL OUTLET. THESE MOVING PARTS MAY BEGIN TO MOVE AT ANY TIME WHILE THE STOVE IS PLUGGED IN.**

PRE-START-UP CHECK

Remove burn pot, making sure it is clean and none of the air holes are plugged. Clean the firebox, and then reinstall

burn pot. Clean door glass if necessary (a dry cloth or paper towel is usually sufficient). Never use abrasive cleaners on the glass or door. Choose which fuel setting that you wish to operate in. Do this by first pressing the “ON” button, then press the “Heat Range” Up and Down arrows together for approximately 3-4 seconds and release. A “C” or “P” in the first digit of the display will indicate the mode. The “ON” led will be blinking and the display will show “CR-1” or “PR-1”, depending on the mode. The “Heat Range” indicator LED and the “Auto” LED should be lit and the dash in the Heat Range display should be flashing. You will notice the draft fan starts immediately. If you press the “Heat Setting” button up, the draft fan changes speed, increasing speed the higher the heat setting. You should begin to see the igniter, located in the center and behind the burnpot, begin to glow after a short period of time. In CR-1, the auger and agitator will start rotating after a few minutes, allowing for proper fuel ignition. In PR-1, the auger will turn immediately, then the agitator will begin to rotate once the heater reaches operating temperature. Note: The room fan will not operate at this time, as a temperature of at least 110°F must be reached before operating. If proper operation of your heater is confirmed, press the “OFF” button, then fill your hopper with fuel. Ensure there is no foreign matter in your fuel, hopper or burnpot.

BUILDING A FIRE

Never use a grate or other means of supporting the fuel. Use only the burn pot supplied with this heater. Hopper lid must be closed in order for the unit to feed pellets. During the start-up period:

- Make sure the burn pot is free of pellets.
- DO NOT open the viewing door.
- DO NOT add pellets to the burn pot by hand.

NOTE: During the first few fires, your stove will emit an odor as the high-temperature paint cures or becomes seasoned to the metal. Maintaining smaller fires will minimize this. Avoid placing items on the stovetop during this period because the paint could be affected. Attempts to achieve heat output rates that exceed heater design specifications can result in permanent damage to the heater.

OPTIMAL OPERATION

This pellet stove has been certified by the US EPA to meet strict 2020 guidelines. To Insure this unit produces the optimal minimal emissions, it is critical to follow the following guidelines. To achieve a “high burn” your stove should be set on setting 5 with the damper fully open. To achieve a “medium burn” your stove should be set

on setting 1 with the damper fully closed. To achieve a “low burn” your stove should be set on setting 1 with the damper closed. Settings 2, 3 & 4 will give you a higher heat output above medium and the damper should be open for these settings. If the door is opened while the stove is in operation it must be closed within 30 seconds or the stove will shut down. If the stove shuts down push the “On/Off” button to re-start your stove. The stove will have to fully shut down and turn off before you will be able to restart the stove.

IGNITOR

- Close all doors, lids, and cleanouts.
- Press the “ON” button and select desired heat range. This will start the ignition sequence.
- At this point, the igniter will come on and run for preset time limit (approximately 9 minutes). The auger will begin to turn and feed fuel into the burnpot. After the 9 minutes or if the heater reaches operating temperature, the igniter will shut off and normal operation will begin.
- Make fine adjustments to the air/fuel with the damper located centered, under the hearth.
- Once the heater reaches warm temperature, the room fan will start to circulate air into the room.
- If you would like to increase the life of your ignitor, you can run your heater in the “CR” mode. However, you must place pellets in the burnpot, up to the igniter level as shown in the illustration below for auto ignition. Close the door and press the “ON” button. The igniter only runs approximately half the time in “CR” as oppose to the “PR” mode.

OPENING DOOR

CAUTION:
<ul style="list-style-type: none"> • DO NOT OPERATE YOUR STOVE WITH THE VIEWING DOOR OPEN. THE AUGER WILL NOT FEED PELLETS UNDER THESE CIRCUMSTANCES AND A SAFETY CONCERN MAY ARISE FROM SPARKS OR FUMES ENTERING THE ROOM. • THE DOOR MUST BE CLOSED AND SEALED DURING OPERATION.

If the door is opened while the stove is in operation it must be closed within 30 seconds or the stove will shut down. If the stove shuts down push the “On/Off” button to re-start your stove. The stove will have to fully shut down and turn off before you will be able to restart the stove.

TAMPER WARNING

This wood heater has a manufacturer-set minimum low burn rate that must not be altered. It is against federal regulations to alter this setting or otherwise operate this wood heater in a manner inconsistent with operating instructions in this manual.

REFUELLING

CAUTION:

- **THE HOPPER AND STOVE TOP WILL BE HOT DURING OPERATION; THEREFORE, YOU SHOULD ALWAYS USE SOME TYPE OF HAND PROTECTION WHEN REFUELING YOUR STOVE.**
- **DO NOT TOUCH THE HOT SURFACES OF THE STOVE. EDUCATE ALL CHILDREN ON THE DANGERS OF A HIGH-TEMPERATURE STOVE. YOUNG CHILDREN SHOULD BE SUPERVISED WHEN THEY ARE IN THE SAME ROOM AS THE STOVE.**
- **NEVER PLACE YOUR HAND NEAR THE AUGER WHILE THE STOVE IS IN OPERATION.**
- **WE RECOMMEND THAT YOU NOT LET THE HOPPER DROP BELOW 1/4 FULL.**

WARNING:

- **KEEP HOPPER LID CLOSED AT ALL TIMES EXCEPT WHEN REFILLING.**
- **DO NOT OVERFILL HOPPER.**

SHUTDOWN PROCEDURE

WARNING:

NEVER SHUT DOWN THIS UNIT BY UNPLUGGING IT FROM THE POWER SOURCE.

Pressing the OFF button will cause the heater to enter a shutdown mode. If the heater has reached operating temperature, the “OFF” Indicator will blink until the shutdown procedure succeeds in lowering the heater temperature. The Room Fan will stay on to cool the heater, and the Exhaust Fan will stay on to remove smoke and heat from the combustion chamber. The Agitator will rotate continuously until shutdown is complete. The Auger will bump the fuel out every few seconds to prevent the fuel in the auger from burning. Once the temperature of the burn chamber falls below approximately 90°F and the pressure switch detects that the door is closed, the fans will stop and the Auger will run for a few seconds to purge the auger system of any burned fuel. At this point, the “OFF” Indicator will go out and the heater will turn

completely off. If during burning, the heater reached at least 120°F, the shutdown procedure will include a 15 minute shutdown cycle that will keep the heater in the shutdown state for at least 15 minutes regardless of whether it is cool or pressure is detected. The 15 minute cycle can be turned off by pressing the off button during shutdown. This will cause the system to exit shutdown and return to the “OFF” mode as soon as the door is closed and the heater is cool. Continue to monitor the heater / insert after the shutdown procedure has begun. And remember, varying ambient conditions may result in a lengthy period of time for adequate cool down and the resultant shut down. Be patient, this is normal. The control board is telling the heater / insert to gradually “shut down,” rather than initiate a sudden halt of fuel to the fire pot. In this way, the possibility of smoke entering the home is avoided.

INTERIOR CHAMBERS

- Periodically remove and clean the burn pot and the area inside the burn pot housing. In particular, it is advisable to clean out the holes in the burn pot to remove any build up that may prevent air from moving through the burn pot freely.
- Remove the small clean-out slides in the lower corners of the firebox. Tap the sides of the burn chamber with a wooden stick. Do not tap the firewall behind the burn box as it may damage the ceramic firebrick. Scrape the fly ash from the clean-out chambers toward the front of the burn chamber. Remove the fly ash from the burn chamber and replace the clean-outs.

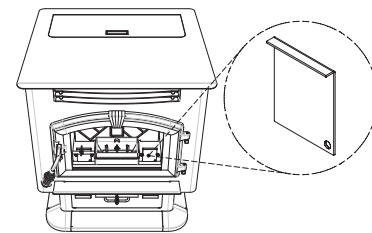

- Remove the ash pan and dump the ash into a metal container.
- Cleaning of the exhaust system will depend upon the ash and debris content of your fuel. If your fuel has a high ash content and/or significant debris in it, your exhaust system will require weekly cleaning. Cleaner fuels will allow for monthly cleaning of the exhaust system. Remove the exhaust pipe from the back of your heater and remove any ash that may have collected in the pipes. Replace the pipes to the heater and seal with high temperature seal tape. If you have installed proper clean out tees you will not have to take the chimney sections apart.

NEVER OPERATE THIS PRODUCT WHILE UNATTENDED

CAUTION:

- **FAILURE TO CLEAN AND MAINTAIN THIS UNIT AS INDICATED CAN RESULT IN POOR PERFORMANCE, SAFETY HAZARDS, FIRE, AND EVEN DEATH.**
- **NEVER PERFORM ANY INSPECTIONS, CLEANING, OR MAINTENANCE ON A HOT STOVE.**
- **DISCONNECT THE POWER CORD BEFORE PERFORMING ANY MAINTENANCE! NOTE: TURNING THE ON/OFF SWITCH TO "OFF" DOES NOT DISCONNECT ALL POWER TO THE ELECTRICAL COMPONENTS OF THE STOVE.**
- **DO NOT OPERATE STOVE WITH BROKEN GLASS, LEAKAGE OF FLUE GAS MAY RESULT.**
- **ATTEMPTS TO ACHIEVE HEAT OUTPUT RATES THAT EXCEED HEATER DESIGN SPECIFICATIONS CAN RESULT IN PERMANENT DAMAGE TO THE HEATER.**

CREOSOTE FORMATION, INSPECTION, & REMOVAL

CAUTION:

THE EXHAUST SYSTEM SHOULD BE CHECKED MONTHLY DURING THE BURNING SEASON FOR ANY BUILD-UP OF SOOT OR CREOSOTE.

When any wood is burned slowly, it produces tar and other organic vapors, which combine with expelled moisture to form creosote. The creosote vapors condense in the relatively cool chimney flue or a newly started fire or from a slow-burning fire. As a result, creosote residue accumulates on the flue lining. When ignited, this creosote makes an extremely hot fire, which may damage the chimney or even destroy the house. Despite their high efficiency, pellet stoves can accumulate creosote under certain conditions. The chimney connector and chimney should be inspected by a qualified person annually or per ton of pellets to determine if a creosote or fly ash build-up has occurred. If creosote has accumulated, it should be removed to reduce the risk of a chimney fire. Inspect the system at the stove connection and at the chimney top. Cooler surfaces tend to build creosote deposits quicker, so it is important to check the chimney from the top as well as from the bottom. The creosote should be removed with a brush specifically designed for the

type of chimney in use. A qualified chimney sweep can perform this service. It is also recommended that before each heating season the entire system be professionally inspected, cleaned and, if necessary, repaired. To clean the chimney, disconnect the vent from the stove.

FLY ASH

This accumulates in the horizontal portion of an exhaust run. Though non-combustible, it may impede the normal exhaust flow. It should therefore be periodically removed.

ASH REMOVAL & DISPOSAL

CAUTION:

ALLOW THE STOVE TO COOL BEFORE PERFORMING ANY MAINTENANCE OR CLEANING. ASHES MUST BE DISPOSED IN A METAL CONTAINER WITH A TIGHT FITTING LID. THE CLOSED CONTAINER OF ASHES SHOULD BE PLACED ON A NON-COMBUSTIBLE SURFACE OR ON THE GROUND, WELL AWAY FROM ALL COMBUSTIBLE MATERIALS, PENDING FINAL DISPOSAL.

Remove the ashes periodically to avoid unnecessary ash build up. Remove ashes when unit has cooled. Ashes should be placed in a metal container with a tight fitting lid. The closed container of ashes should be placed on a noncombustible floor or on the ground, well away from all combustible materials, pending final disposal. If the ashes are disposed of by burial in soil or otherwise locally dispersed, they should be retained in the closed container until all embers have been thoroughly cooled. The container shall not be used for other trash or waste disposal. If combined with combustible substances, ashes and embers may ignite.

SMOKE & CO MONITORS

Burning wood naturally produces smoke and carbon monoxide(CO) emissions. CO is a poisonous gas when exposed to elevated concentrations for extended periods of time. While the modern combustion systems in heaters drastically reduce the amount of CO emitted out the chimney, exposure to the gases in closed or confined areas can be dangerous. Make sure you stove gaskets and chimney joints are in good working order and sealing properly to ensure unintended exposure. It is recommended that you use both smoke and CO monitors in areas having the potential to generate CO.

CHECK & CLEAN THE HOPPER

Check the hopper periodically to determine if there is any sawdust (fines) that is building up in the feed system or pellets that are sticking to the hopper surface. Clean as needed.

DOOR & GLASS GASKETS

Inspect the main door and glass window gaskets periodically. The main door may need to be removed to have frayed, broken, or compacted gaskets replaced by your authorized dealer. This unit's door uses a 1" diameter rope gasket.

BLOWER MOTORS

Clean the air holes on the motors of both the exhaust and distribution blowers annually. Remove the exhaust blower from the exhaust duct and clean out the internal fan blades as part of your fall start-up. If you have indoor pets your power motors should be inspected monthly to make sure they are free of animal hair build up. Animal hair build up in blowers can result in poor performance or unforeseen safety hazards.

PAINTED SURFACES

Painted surfaces may be wiped down with a damp cloth. If scratches appear, or you wish to renew your paint, contact your authorized dealer to obtain a can of suitable high-temperature paint.

GLASS

We recommend using a high-quality glass cleaner. Should a buildup of creosote or carbon accumulate, you may wish to use 000 steel wool and water to clean the glass. DO NOT use abrasive cleaners. DO NOT perform the cleaning while the glass is HOT. Do not attempt to operate the unit with broken glass. Replacement glass may be purchased from your U.S. Stove dealer. If the glass is broken, follow these removal procedures:

1. Once the heater has cooled, remove the door from the heater.
2. Remove the rope gasket from the door followed by the nuts holding the glass retainer in place.
3. While wearing gloves, carefully remove any loose pieces of glass from the door frame.
4. Replace the glass and gasket, making sure the gasket runs the full perimeter of the glass edge.
5. Re-install the retainer and rope gasket using high-temperature silicone to adhere the gasket to the door.
6. Never use substitute materials for the glass.

DO NOT abuse the door glass by striking, slamming, or similar trauma. Do not operate the stove with the glass removed, cracked, or broken.

FALL START UP

Prior to starting the first fire of the heating season, check the outside area around the exhaust and air intake systems for obstructions. Clean and remove any fly ash from the exhaust venting system. Clean any screens on the exhaust system and on the outside air intake pipe. Turn all of the controls on and make sure that they are working properly. This is also a good time to give the entire stove a good cleaning throughout.

SPRING SHUTDOWN

After the last burn in the spring, remove any remaining pellets from the hopper and the auger feed system. Scoop out the pellets and then run the auger until the hopper is empty and pellets stop flowing (this can be done by pressing the "ON" button with the viewing door open). Vacuum out the hopper. Thoroughly clean the burn pot, and firebox. It may be desirable to spray the inside of the cleaned hopper with an aerosol silicone spray if your stove is in a high humidity area. The exhaust system should be thoroughly cleaned.

MAINTENANCE SCHEDULE

Use the following as a guide under average use conditions. Gaskets around door and door glass should be inspected and repaired or replaced when necessary.

	Daily	Weekly	Monthly or as needed
Burn Pot	Stirred	Empty	
Combustion Chamber		Brushed	
Ashes		Check	Empty
Interior Chambers			Vacuumed
Combustion Blower Blades			Vacuumed / Brushed
Convection Blower Impeller			Vacuumed / Brushed
Vent System			Cleaned
Gaskets			Inspected
Glass	Wiped	Cleaned	
Hopper (end of season)			Empty & Vacuumed

CONTROL BOARD FUNCTIONS

START-UP SEQUENCE OF EVENTS		
Once the control panel is turned on, a timer begins that will start, stop and continue operation of the heater as a preset temperature is achieved.		
COMPONENT	OPERATION START	OPERATION END
Draft Fan	Starts Immediately	Will continue until shutdown. Shutdown will occur when the operating temperature is below approx. 90 degrees.
Agitator	Begins to turn once the heater reaches operating temperature	Will continue intermediately, as determined by the "HEAT SETTING", until shutdown.
Auger	In PR-1 mode: Auger turns immediately. In CR-1: Three minutes after starting, the auger will begin to turn	The auger will continue at the feed rate specified by the "HEAT SETTING". NOTE: Safety switches, HI limit and vacuum sensor, must be activated to continue proper operation.
Room Fan	Begins to run when heater reaches operating temperature	Will continue to operate until the heater cools down to below approx. 90 degrees. This may take several hours.
Automatic Shutdown	If after 15 minutes, the heater has not reached the preset operating temperature, the unit will begin to automatically shut down.	Should the timer expire before the preset operating temperature is achieved, simply reset the heater by pressing the "ON" button.
Normal Operation	If after 15 minutes the preset operating temperature of approx. 110 degrees is achieved, normal operation will continue.	Operation will continue until either the heater's control is to the "OFF" position, or the operating temperature falls below approx. 90 degrees. At such time the heater will default to the "Automatic Shut Down".
Igniter	Starts immediately	Will continue operation for a preset time, then shut-off

SHUTDOWN SEQUENCE OF EVENTS		
Once the Heater has reached the normal operating temperature and switched to the "OFF" position, the unit will initiate a slow down, reducing the fuel rate until the heater's "LOW LIMIT SAFETY" sensor tells the control board it is safe to shutdown.		
COMPONENT	SHUTDOWN	OPERATION END
Draft Fan	Unchanged operation until preset "OFF" temperature is achieved.	Continues until the operating temperature falls below approx. 90 degrees. May take several hours.
Agitator	Rotates continuously until preset "OFF" temperature is achieved.	Continues until the operating temperature falls below approx. 90 degrees.
Auger	Slows down to a reduced fuel setting until preset "OFF" temperature is achieved.	The auger will continue at the reduced feed rates until the operating temperature falls below approx. 90 degrees. NOTE: Safety switches, HI limit and vacuum sensor, must be activated to continue proper operation.
Room Fan	Unchanged operation until preset "OFF" temperature is achieved.	Will continue to operate until the heater cools down to below approx. 90 degrees. This may take several hours.
Automatic Shutdown	If the heater's "HI LIMIT" sensor snaps open, this will cause an automatic shutdown. An error code will be displayed (Err1). NOTE: "HI LIMIT" errors are usually the result of operating at the highest heat setting for long periods of time, room fan failure or loose wire connection.	It is rare that the HI LIMIT temperature is reached. However, should this error occur, let the heater cool down for an hour then restart.

ERROR CODES & DISPLAY INDICATORS



CAUTION: WHEN PERFORMING ANY INTERNAL ELECTRICAL MAINTENANCE

- **MOVING PARTS INSIDE OF THE CABINET MAY CAUSE INJURY. DO NOT OPERATE UNIT WITH PANELS REMOVED OR OPEN.**
- **HOT PARTS. DO NOT OPERATE THE UNIT WITH PANEL OPEN.**
- **RISK OF ELECTRIC SHOCK. DISCONNECT POWER BEFORE SERVICING UNIT.**
- **IN THE EVENT OF COMPONENT FAILURE, REPLACE WITH THE ORIGINAL FACTORY EQUIPMENT.**

Error Code	Error Description	Possible Causes
Err1	The high limit temperature sensor has tripped.	Inadequate ventilation. Room fan failure. Exhaust Blockage. Electrical Open in the over temperature switch or wiring.
Err2	The low limit temperature sensor has tripped.	Hopper Empty. Auger output failure or jam. Poor flame or fuel quality caused fire to burn too slowly or go out. Electrical open in low temperature switch or wiring. Fire was not well established before the PCB's programmed time limit expired.
Err3	The heater was unable to reach the Room Fan On temperature within the startup time.	Poor flame or fuel quality caused fire to burn too slowly or go out. Auger output failure or jam Hopper empty on startup.
Err4	The power failed while the heater was hot, and when power was restored, the fire was out.	Electrical Open in low temperature switch or wiring. Power loss
Err5	The Auger output fuse has blown.	Auger motor jammed or bad.
Err6	The Agitator output fuse has blown.	Agitator motor jammed or bad.
Err7	The Draft Fan (Exhaust Fan) output fuse has blown.	Draft Fan motor jammed or bad.
Err8	The Room Fan output fuse has blown.	Room fan motor jammed or bad.
Err9	Zero Crossing Input failed	AC supply frequency out of range.
Err10	The Igniter output fuse has blown	Igniter output has shorted/blown or igniter overload.

DISPLAY INDICATORS

Several situations or events are indicated in normal operation by blinking display indicators or segments in the display:

Flashing On Indicator: This means that the heater is in the “Start Up” awaiting for the ignition procedure to complete.

Flashing Off Indicator: This indicates that the heater is in the “Shutdown” state waiting for the OFF button, or for a 15 minute period after the heater was turned off, or for the heater to cool down, or for the door to be closed.

Flashing Dash In Heat Range Display: This indicates that the heater is in the normal run mode and is ramping from the current heat range setting to the target heat range setting. Once the ramp is complete, the dash will stop flashing. For ramping from heat range 1 to 5, the default time is 12 minutes (with a 90 second ramp time).

Flashing Heat Range Value In “Heat Range” Display: For example, if the display is showing “Hr-3” and the ‘3’ is blinking, this indicates that the heater thermostat input is open and not calling for heat. While this is happening, the actual heat range value is 1 (low).

Flashing Automatic Mode Indicator: This indicates that the heater is in normal operation and is running in the automatic mode. However, either the Draft Fan or Auxiliary setting is manually configured.

Flashing Draft Fan Setting Indicator: This indicates that the heater is in normal operation and that the vacuum sensor detects a loss of pressure either because the door is open or because there is a negative pressure in the room with respect to the exhaust.

Flashing Aux Indicator: This indicates that the igniter is on during the lighting stage.

Quick (changes twice per second) Flashing Heat Range Setting Indicator: This indicates that the heater is in normal operation and that an over temperature condition exists causing the fuel to stop.

Slow (changes once per second) Flashing Heat Range Setting Indicator: This indicates that the heater is in a cutback condition in an attempt to prevent an over temperature shutdown.

FACTORY DEFAULTS

To return the control to its original factory default settings, press and hold the AUX UP and AUX DOWN buttons together for three seconds.

HOW TO ORDER REPAIR PARTS

For Parts Assistance Call: 800-750-2723 Ext 5051 or Email: parts@usstove.com

The information in this owner’s manual is specific to your unit. When ordering replacement parts the information in this manual will help to ensure the correct items are ordered. Before contacting customer service write down the model number and the serial number of this unit. That information can be found on the certification label attached to the back of the unit. Other information that may be needed would be the part number and part description of the item(s) in question. Part numbers and descriptions can be found in the “Repair Parts” section of this manual. Once this information has been gathered you can contact customer service by phone 1-800-750-2723 Ext 5051 or Email parts@usstove.com.

Model Information	
Model Number	
Serial Number	

TROUBLESHOOTING GUIDE



- Disconnect the power supply before performing any maintenance! NOTE: Turning the heater to “OFF” does not disconnect the power to all of the electrical components of the heater.
- Never try to repair or replace any part of the heater unless instructions for doing so are given in this manual. All other work should be done by a trained technician.

PROBLEM	CAUSE: Too rich air/fuel mixture
Orange, lazy flame, excessive fuel build-up in the burnpot.	<p>Clean out the burnpot</p> <p>Make sure the cleanouts on each side of the damper are closed completely.</p> <p>Not enough combustion air. Adjust the air damper to a more open position.</p> <p>Make sure that the viewing door is closed and sealed properly. If not, adjust the door catch or replace the gasket.</p> <p>Check that all outside connections are clear of any obstructions.</p> <p>Check the exhaust system, clean as needed.</p>
PROBLEM	Cause: Burnpot out of fuel
Fire goes out or heater shuts down	<p>Hopper is empty, refill the hopper</p> <p>Loss of draft pressure. Make sure the viewing door is closed and sealed properly. Check the outside connections for any obstructions. Check the exhaust system; clean as needed.</p> <p>Check that the pressure switch connection to the firebox is free of ashes or clear of any obstructions.</p> <p>Auger system may be jammed or there is a “bridging” of fuel in the hopper preventing fuel flow into the auger feed system.</p> <p>Too much combustion air. Adjust damper to a more closed position.</p>
PROBLEM	Cause: Auto-Start Igniter fails to ignite the fuel in the burnpot.
Heater does not start a fire when the “ON” button is pressed.	<p>Check the pellets quality. If moist or damp, replace with dryer fuel.</p> <p>Check that the auto-start igniter port is not blocked with ash or soot. (The igniter is located behind the burnpot.)</p> <p>The auto-start igniter should glow on start-up. If you can not visible see the igniter glowing, then it may need to be replaced or there is a problem with the electrical system. Check wiring.</p> <p>Loss of draft pressure. Make sure the viewing door is closed and sealed properly. Check the outside connections for any obstructions. Check the exhaust system; clean as needed.</p>
PROBLEM	Cause: Not enough combustion air or fuel has too much moisture.
Viewing glass becomes black shortly after start-up.	<p>Adjust the air damper to a more open position.</p> <p>Use a fuel with less moisture content.</p>
PROBLEM	Cause: Not enough combustion air or fuel has too much moisture.

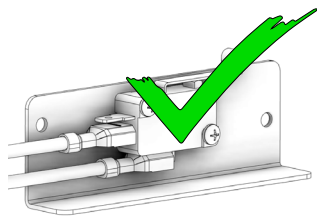
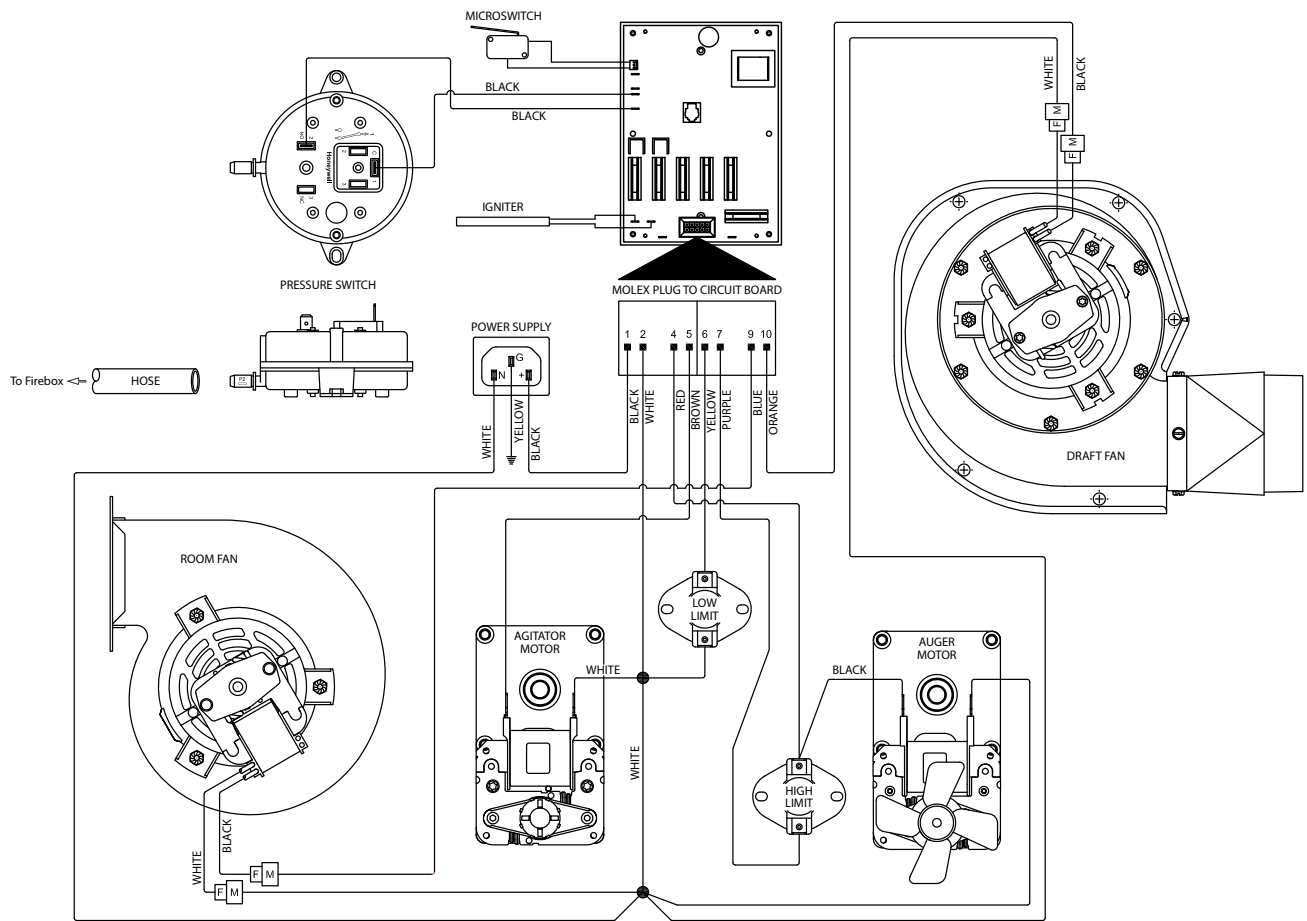

CORRECT

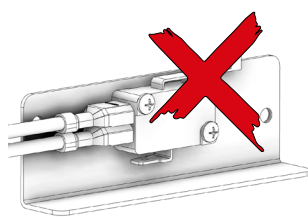

WRONG

Ensure the wires are connected to the bottom two prongs of the hopper switch as shown.

WIRING SCHEMATIC

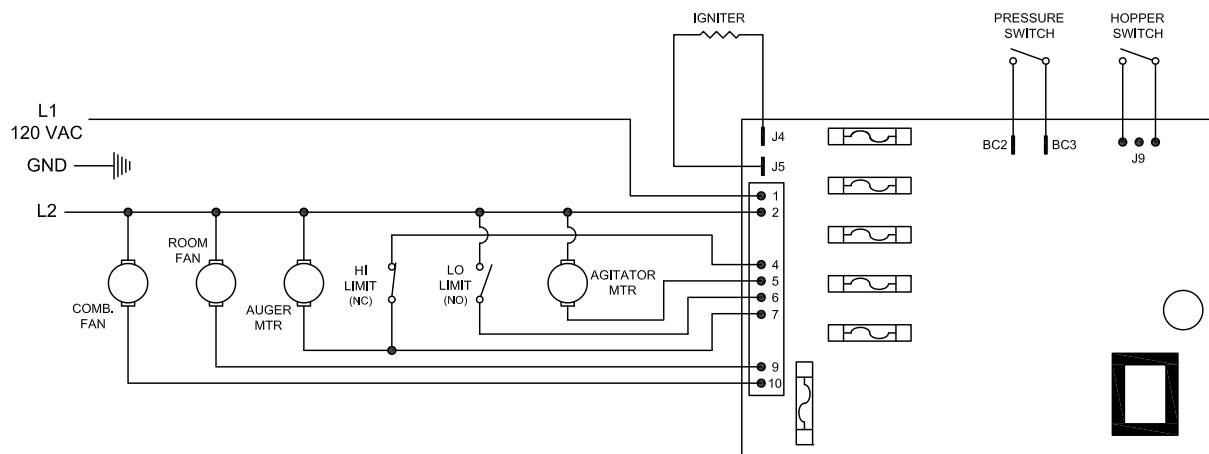

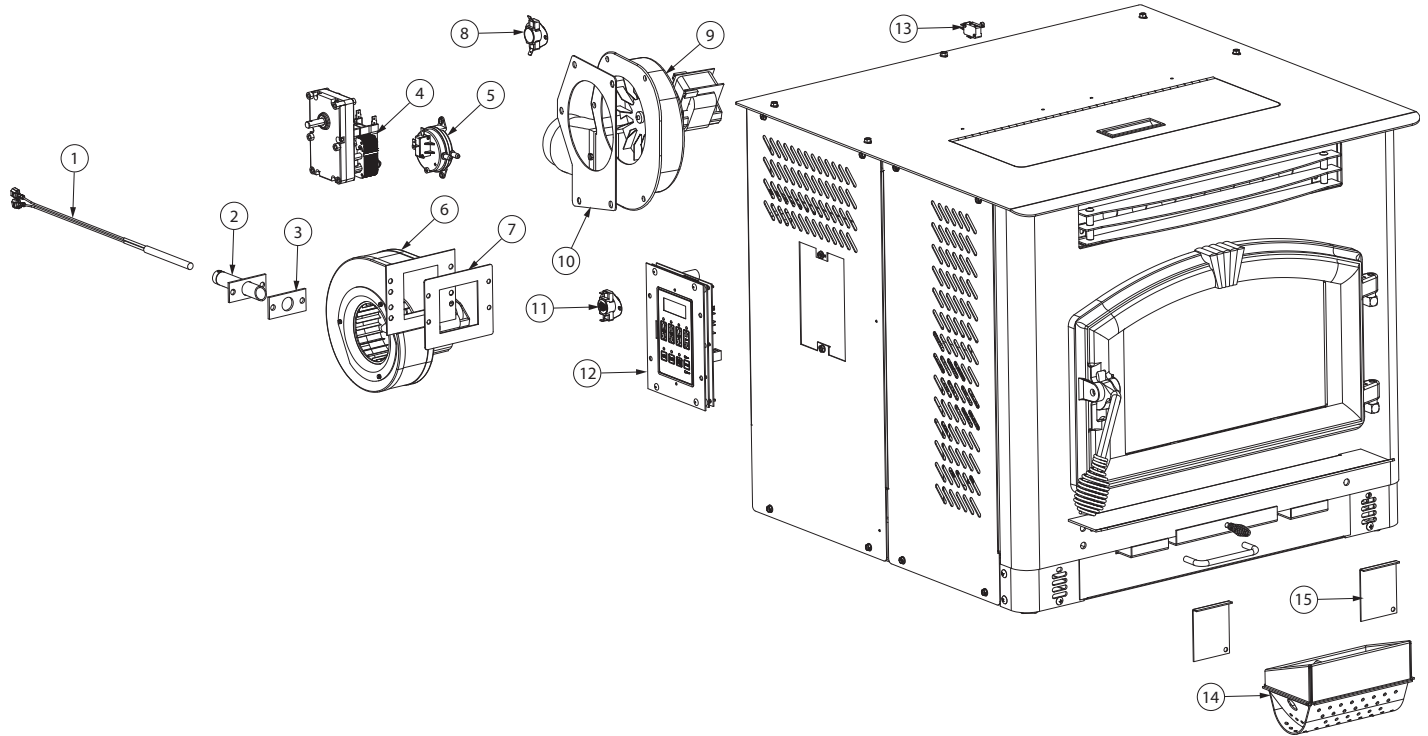

Key	Part #	Description	Qty
1	80543	Igniter Cartridge	1
2	69593	Igniter Tube Weldment	1
3	88118	Igniter Flange Gasket	1
4	80456	Drive Motor (Agitator)	1
5	80549	Pressure Switch	1
6	80472	Distribution Blower	1
7	88106	Distribution Blower Gasket	1
8	80381	110°F Snap Disc (Low Limit)	1
9	80473	Exhaust Blower	1
10	88100	Exhaust Blower Gasket	1
11	80390	170°F Snap Disc (High Limit)	1
12	80575	PCB, Circuit Board	1
13	80491	Micro Switch	1
14	891660	Burnpot	1
15	25524	Ash Cleanout (Inner)	2

To order parts:

Call 1-800-750-2723 Ext 5051 or

Email to: parts@usstove.com

IN ORDER TO MAINTAIN WARRANTY, COMPONENTS MUST BE REPLACED USING USSC PARTS PURCHASED THROUGH YOUR DEALER OR DIRECTLY FROM USSC. USE OF THIRD PARTY COMPONENTS WILL VOID THE WARRANTY.

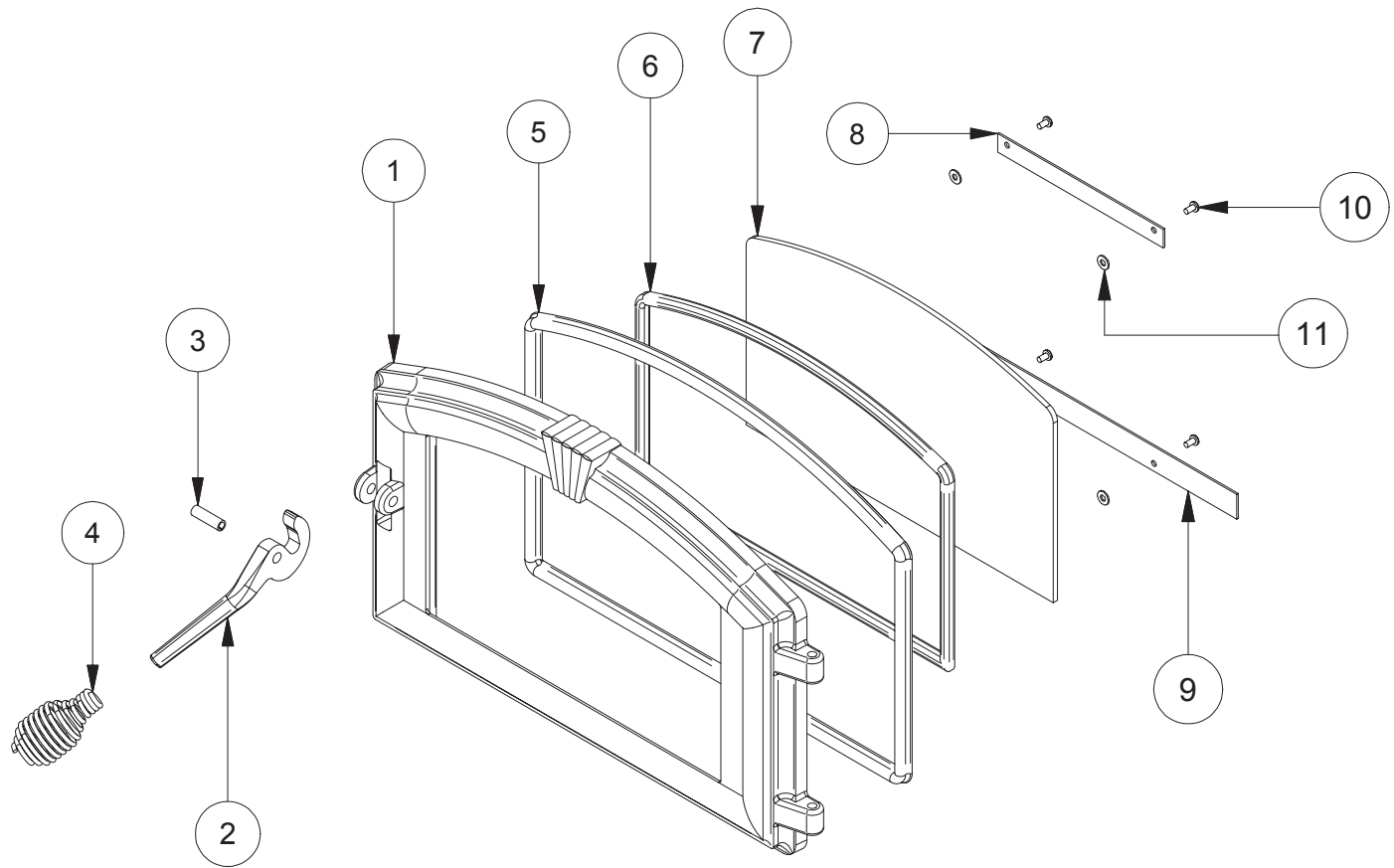

Key	Part #	Description	Qty
1	25491	Feed Door	1
2	25492	Handle, Door	1
3	83506	Roll Pin, 3/8 x 1-1/4	1
4	891135	Handle, Spring (Parts Bag)	1
5	88112	Gasket, 1/2" Sq. Rope	5 ft
6	88087	Gasket, Glass (1 x 3/16)	4 ft
7	891131	Glass Ceramic	1
8	25464	Retainer, Top Glass	1
9	25465	Retainer, Bottom Glass	1
10	83202	Machine Screw	4
11	83278	#10 Flat Washer	4

To order parts:

Call 1-800-750-2723 Ext 5051 or

Email to: parts@usstove.com

IN ORDER TO MAINTAIN WARRANTY, COMPONENTS MUST BE REPLACED USING USSC PARTS PURCHASED THROUGH YOUR DEALER OR DIRECTLY FROM USSC. USE OF THIRD PARTY COMPONENTS WILL VOID THE WARRANTY.

SERVICE RECORD



It is recommended that your heating system is serviced regularly and that the appropriate Service Interval Record is completed.

SERVICE PROVIDER

Before completing the appropriate Service Record below, please ensure you have carried out the service as described in the manufacturer's instructions. Always use the manufacturer's specified spare part when replacement is necessary.

Service 01	Date: _____
Engineer Name: _____	
License No.: _____	
Company: _____	
Telephone No.: _____	
Stove Inspected: <input type="checkbox"/>	Chimney Swept: <input type="checkbox"/>
Items Replaced: _____	

Service 02	Date: _____
Engineer Name: _____	
License No.: _____	
Company: _____	
Telephone No.: _____	
Stove Inspected: <input type="checkbox"/>	Chimney Swept: <input type="checkbox"/>
Items Replaced: _____	

Service 03	Date: _____
Engineer Name: _____	
License No.: _____	
Company: _____	
Telephone No.: _____	
Stove Inspected: <input type="checkbox"/>	Chimney Swept: <input type="checkbox"/>
Items Replaced: _____	

Service 04	Date: _____
Engineer Name: _____	
License No.: _____	
Company: _____	
Telephone No.: _____	
Stove Inspected: <input type="checkbox"/>	Chimney Swept: <input type="checkbox"/>
Items Replaced: _____	

Service 05	Date: _____
Engineer Name: _____	
License No.: _____	
Company: _____	
Telephone No.: _____	
Stove Inspected: <input type="checkbox"/>	Chimney Swept: <input type="checkbox"/>
Items Replaced: _____	

Service 06	Date: _____
Engineer Name: _____	
License No.: _____	
Company: _____	
Telephone No.: _____	
Stove Inspected: <input type="checkbox"/>	Chimney Swept: <input type="checkbox"/>
Items Replaced: _____	

Service 07	Date: _____
Engineer Name: _____	
License No.: _____	
Company: _____	
Telephone No.: _____	
Stove Inspected: <input type="checkbox"/>	Chimney Swept: <input type="checkbox"/>
Items Replaced: _____	

Service 08	Date: _____
Engineer Name: _____	
License No.: _____	
Company: _____	
Telephone No.: _____	
Stove Inspected: <input type="checkbox"/>	Chimney Swept: <input type="checkbox"/>
Items Replaced: _____	

