

# Installation Instructions

.....

## LT10 Lockable Trimmer Rack

for Utility Landscape Trailers

Before you begin installing:

1. Read and understand these instructions completely.
2. Verify that you have received all the parts listed in the bill of materials.

**WARNING**

Always wear safety glasses when using power tools.

### Tools Required:

- (2) 9/16" Wrenches and/or Sockets
- Electric Drill
- 13/32" Drill Bit
- Carpenter's Square
- Tape Measure
- (2) C-clamps
- Hack Saw

**1.** Clamp the locking and nonlocking uprights to the trailer side rail approximately 28" to 34" apart with the base of the upright on the trailer floor. The locking upright may be assembled on the left or right of the nonlocking upright. Verify the uprights are square to the trailer deck in both directions with a carpenter's square. **Note: If bent shaft trimmers are used, the uprights need to be mounted closer together than if straight shaft trimmers are used.**

**2.** Assemble a line trimmer to the rack to verify the distance between the uprights is correct for the model of trimmer you wish to hold. The large hook on the nonlocking upright should engage the trimmer's grip and the smaller hook on the locking upright should engage the shaft of the trimmer. **Do not clamp on or near the throttle trigger of the trimmer.** With the trimmer assembled in position, verify that the lock assembly can rotate freely over the trimmer shaft.



**3.** After determining the position of the uprights, mark center of the two holes in each upright base on the trailer deck.

**WARNING**

Check for locations of brake lines and electrical wiring etc., before drilling any holes. Any damage to trailer during installation is the installer's sole responsibility.

**4.** Remove the uprights from the trailer and use a 13/32" drill bit to drill four holes in your trailer deck as marked.

**5.** Assemble the uprights to the trailer with four 3/8-16 x 2-1/2" cap screws, eight 3/8" flat washers and four 3/8-16 nylock nuts. Do not tighten screws at this time!

**6.** Clamp the two uprights to the rail of the trailer. Make sure the uprights are square to the rail and the deck of the trailer with a square.

- 7.** With the uprights clamped into position drill a 13/32" hole through the center of each upright and the trailer rail.
- 8.** Fasten each upright to the trailer rail with a 3/8-16 x 2" cap screw, two 3/8" flat washers, and a 3/8-16 nylock nut. Tighten all six screws.
- 9.** Loosely assemble the top connecting angle to an upright using hardware supplied and hold horizontally. Mark the angle on the outside of the second upright. Remove and cut off excess material.
- 10.** Drill a 13/32" hole in the center of the angle's web 1/2" from the end of the angle.
- 11.** Assemble top connecting angle using two 3/8-16 x 2" cap screws, two 3/8" flat washers and two 3/8-16 nylock nuts and tighten.

### Bill of Materials

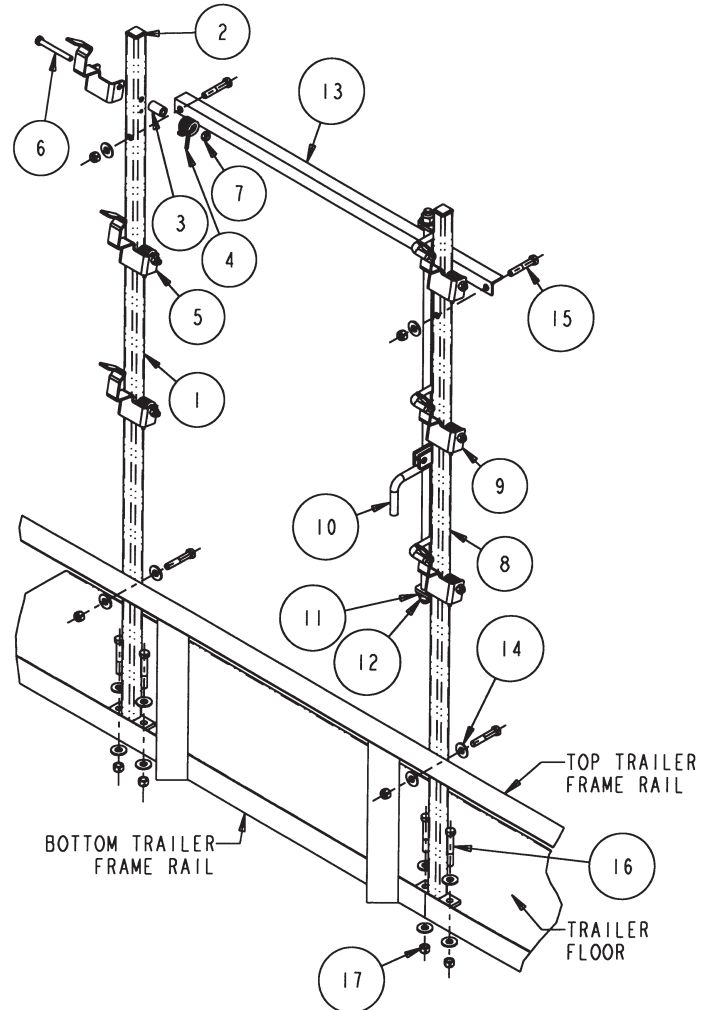

### Bill of Materials

ITEM	PART NO.	QTY.	DESCRIPTION
1	3004208	1	Post, Vertical Nonlocking, Trimmer Rack
2	3006655	2	Plug, Plastic Finish, 1" Sq Tube
3	3004083	6	Guide, Spring
4	3005938	6	Spring, Torsion Trimmer Rack
5	3005286	3	Hook, Grip Pivot
6	c	6	Screw, HHC 5/16-18 x 2-3/4" Gr 5 Zn
7	-	6	Nut, Nylock 5/16-18 Zn
8	3004091	1	Tube, Vertical, Locking, Welded
9	3004082	3	Hook, Pivot
10	3004090	1	Lock, Trimmer Rack, Finished
11	-	2	Washer, Flat 1/2" SAE Zn
12	-	2	Nut, Nylock 1/2-13 Zn
13	3004466	1	Angle, Top Connecting, LT10
14	-	14	Washer, Flat 3/8" USS Zn
15	-	4	Screw, HHC 3/8-16 x 2 Gr 5 Zp
16	-	4	Screw, HHC 3/8-16 x 2-1/2 Gr 5 Zp
17	-	8	Nut, Nylock 3/8-16 x 7/16 Zn

### Warranty

Buyers Products Co. warrants all truck/trailer hardware manufactured or distributed by it, to be free from defects in material and workmanship for a period of one year from date of shipment. Parts must be properly installed and used under normal conditions. Any product which has been altered, including modification, misuse, accident or lack of maintenance will not be considered under warranty. Normal wear is excluded. The sole responsibility of Buyers Products Co. under this warranty is limited to repairing or replacing any part or parts which are returned, prepaid, and are found to be defective by Buyers Products Co. Authorization from Buyers Products Co. must be obtained before returning any part. No charges for transportation or labor performed on Buyers' products will be allowed under this warranty.