



Important Safety Information

Read and understand all safety precautions and instructions before use.

- The universal Fast Hitch System is designed for Cat 1 and Cat 2-- 3 point hitches.
- Check universal Fast Hitch System before each and every use for signs of wear. Do not use if damaged or if not working properly.
- The universal Fast Hitch System is designed to be used by adults only.
- Keep children away from tractors and implements.



Instructions:

1. Determine the category of hitch you have on your tractor. Fast Hitch includes bushings to adapt category 1 hitch arms. Fast Hitch includes bushings to adapt category 1 implements to category 2.
2. Attach the main body of the fast hitch to 3 pt. arms by using bolt # 4 and nut # 14 and tighten securely.
3. Center the hitch by using bolt # 10 on top and bolt # 15 on the bottom along with jamb nut # 11 and secure. Tighten jamb nut after adjustment.
4. Use 3 each of bolt # 2 and jamb nut # 3 for each side of the hitch assembly. Tighten the bolts against the hitch arm assembly so the Fast Hitch is tight against the 3 point arms. Tighten jamb nuts.
5. Hook strap # 20 to each side of the Fast Hitch to keep lift arms together.
6. Back up your tractor to the implement and lift the 3 point arms. The spring loaded toggle should trap the pins of your implement. Make sure you have the proper pin size for the Fast Hitch so there is no play between the pins and Fast Hitch opening. Bushings are supplied if you need to adapt to Category 2. Secure top link and you are ready to use your Fast Hitch.
7. Check to make sure bolts and jamb nut are tight after 15 minutes of use. After checking the first time, complete the same process every hour.
8. To unhook your implement, hook the cable lanyard to the rod from the spring loaded toggle. Unhook your top link and lower the 3 pt. arms. Drive away from your implement slowly.

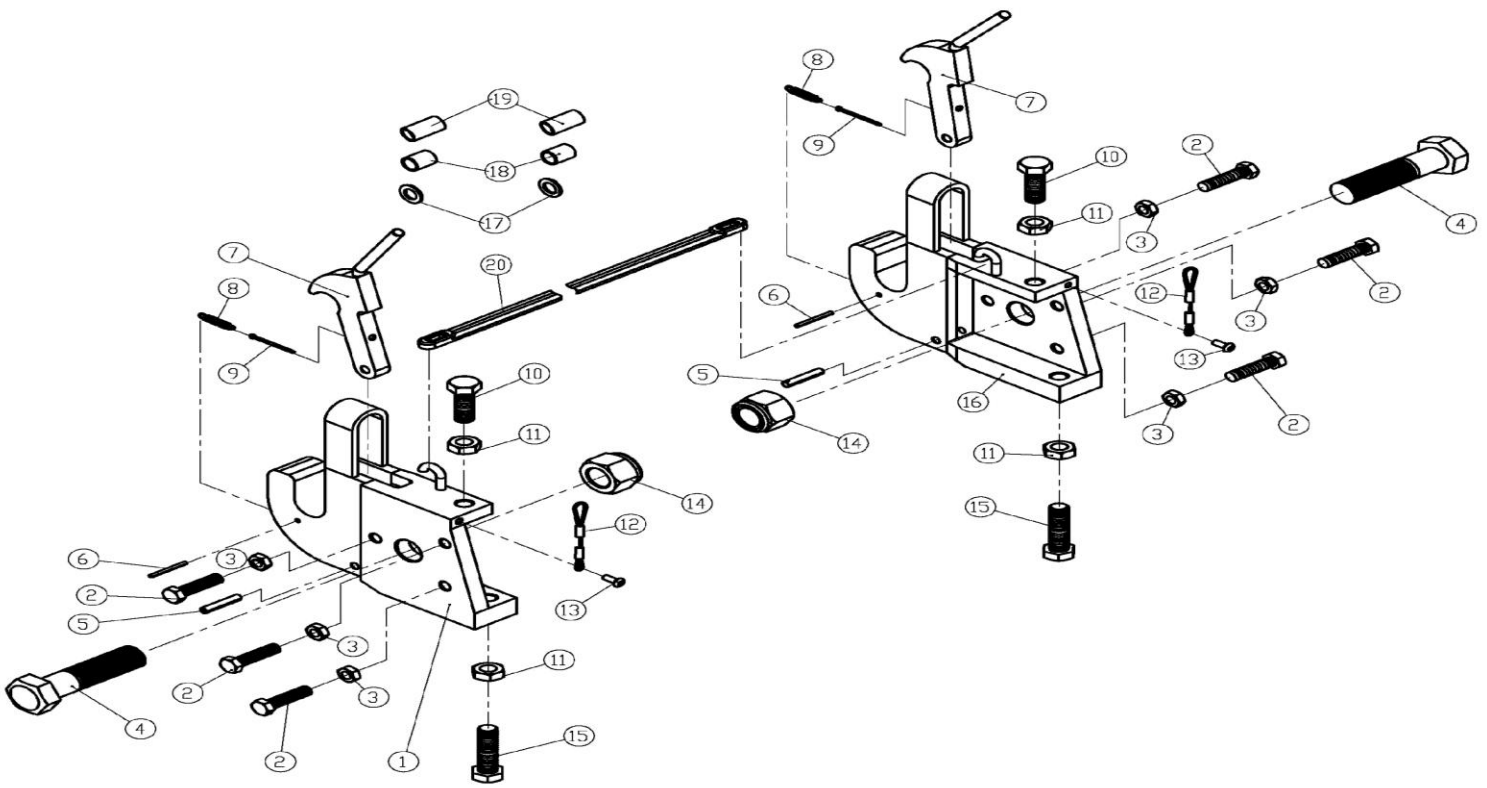

Ref. #	Qty	Part #	Description
1	1	FTF-01FH-001	Right Main Body
2	6	FTF-01FH-002	Hex Bolt 3/8-16X1-1/2"
3	6	FTF-01FH-003	Nut 3/8-16
4	2	FTF-01FH-004	Hex Bolt 7/8-9X3-3/8"
5	2	FTF-01FH-005	Roll Pins 0.236"X1.18"
6	1	FTF-01FH-006	Roll Pins 0.118"X1.18"
7	2	FTF-01FH-007	Lock Hook
8	2	FTF-01FH-008	Hook Spring
9	2	FTF-01FH-009	Cotter Pins 0.11"X1.18"
10	2	FTF-01FH-010	Hex Bolt 1/2-13X1-1/2"
11	4	FTF-01FH-011	Nut 1/2-13
12	2	FTF-01FH-012	cabl lanyard
13	2	FTF-01FH-013	Screws 10-24X1/2"
14	2	FTF-01FH-014	Lock Nut 7/8-9
15	2	FTF-01FH-015	Hex Bolt 1/2-13X2"
16	1	FTF-01FH-016	Left Main Body
17	2	FTF-01FH-017	Flat Washer 1-1/2"X7/8"X1/8"
18	2	FTF-01FH-018	Short Bushing 1-1/8"X7/8"X1-3/8"
19	2	FTF-01FH-019	Long Bushing 1-1/8"X 7/8"X 2"
20	1	FTF-01FH-020	Strap

Category Pin Size	0	1	2
Lift Arm Hole Diameter	5/8"	7/8"	1 1/8"
Implement Pin Size	5/8"	7/8"	1 1/8"
Top Link Pin Size	5/8"	3/4"	1"

WARNING



BAC Industries, Inc. and Field Tuff will not be held liable for any damages, losses, or injury, due to misapplication or misuse of this product or for any other reason. Always wear approved safety glasses, protective clothing, and proper hand and foot protection at all times. Keep all people and pets, or animals clear from work area.

PO BOX 155
Miltona, MN 56354
1-218-943-6290