

Installation Instructions

RM6-Series Receiver Mount Combination Ball Hitch

with Integral Receiver Shank Patent No. 6,139,043

Capacity for Pintle Hook

2,400 lbs. Maximum Vertical Load
12,000 Lbs. Maximum Gross Trailer Weight

Capacity for Ball Hitch

1-7/8" ball dia. - 12,000 lbs. Maximum Gross Trailer Weight
2" ball dia. - 12,000 lbs. Maximum Gross Trailer Weight
2-5/16" ball dia. - 12,000 lbs. Maximum Gross Trailer Weight

WARNING: Maintain adequate vertical (tongue) load to properly control the trailer (generally 10%), but do not exceed the above rated capacities.

Towing Applications

Trailers and equipment designed for over-the-road towing within the stated capacities. For off-road applications, reduce the capacities listed above by 25%, and use in conjunction with a swivel-type drawbar. This pintle hook/ball hitch is well suited for use in the utility and construction industries.

Drawbar Eye/Ball Hitch Dimensions

2½" to 3" I.D. with 1-1/4" to 1-9/16" diameter section, depending on ball diameter / 1-7/8", 2", 2-5/16" SAE J 684 Ball Hitch Coupler

Mounting

1. Use a secure receiver mount of sufficient strength to support the rated capacity of the pintle hook in accordance with S.A.E. J 849B.
2. Secure with a 5/8" diameter bolt or pin, use locknut or locking pin to secure bolt or hitch pin.

Operating Instructions for Pintle Hook

1. Before operating, inspect for proper operation, worn, damaged or missing parts, and secure mounting.
2. Open latch by removing safety pin and lifting lock.
3. Position drawbar eye over the horn of the pintle and lower into place.

WARNING: Do not damage the latch. Be particularly careful with the drawbar when coupling and uncoupling.

4. Push latch closed and insert safety pin.



Operating Instructions for Ball Hitch

1. Before operating, inspect for proper operation, worn, damaged or missing parts, and secure mounting. Correct as required before use.
2. Open latch by removing safety pin, pull upon lock while lifting latch.
3. Replace safety pin in hole to retain latch in open position.
4. Position ball coupler over the proper size ball and lock into place following the instructions of the coupler manufacturer.

WARNING: Other steps and inspections are also required. Consult D.O.T. regulations and American Trucking Association for complete coupling and uncoupling procedures.

Maintenance

For proper performance, the following should be performed every 3000 miles or 3 months, whichever comes first.

1. Clean and inspect for proper operation.
2. Inspect, in particular, the coupling area. Replace when wear exceeds 1/8" (.125") from the original surface profile.
3. Inspect for worn, damaged or missing parts. Replace as required.
4. Regularly lubricate latch and lock pivots with a light oil lubricant.

Ball Replacement

1. Use only Buyers replacement balls.
2. Torque locknut to 350 ft. lbs.
3. Replace prevailing torque locknut when it falls below 70 in. lbs. of torque required to thread onto ball shaft.
4. Check torque specification of ball every 200 miles of towing.

General Information

1. Do not add to, or modify this product.
2. Do not weld on this product.

WARNING: It is the user's responsibility to ensure that the receiver mount is capable of 2,400 lb. vertical load and 12,000 lb. gross trailer weight.

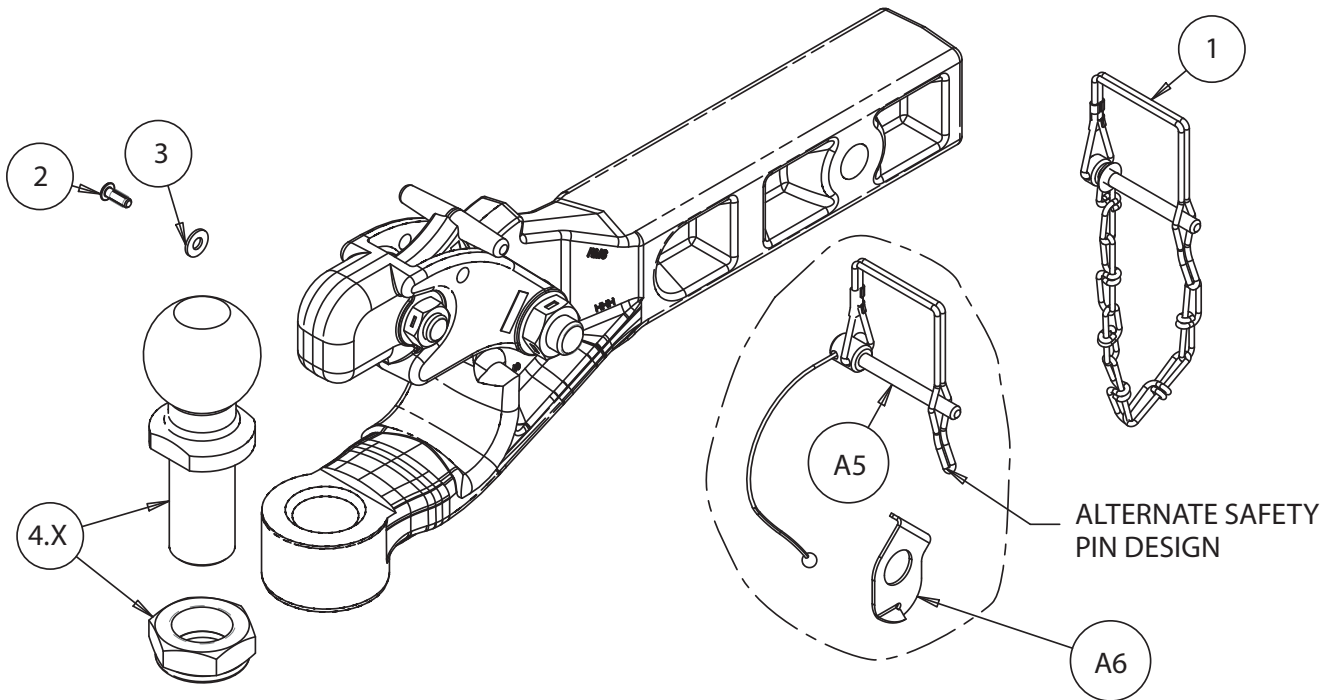
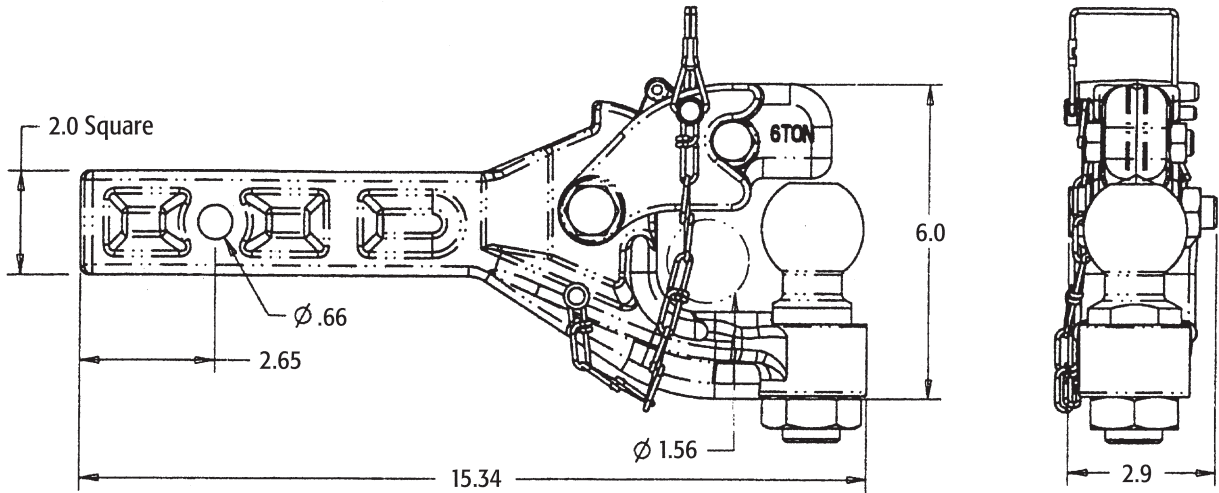

Bill of Materials

ITEM NO.	PART NO.	DESCRIPTION
1	P11C	Pin, 1/4" Safety Zinc w/Chain
2	0081000	Rivet, Drive #10 x 1/2 Zinc
3	0081600	Washer, #10 Flat SAE Zinc
4.1	RB1780	Ball, 1-7/8" Replacement w/Nut
4.2	RB2000	Ball, 2" Replacement w/Nut
4.3	RB2516	Ball, 2-5/16" Replacement w/Nut
4.4	RB50MM	Ball, 50MM Replacement w/Nut
A5	3004987	Pin, 1/4" Safety Zinc w/ Lanyard
A6	3005013	Washer, Lanyard, Large

WARRANTY

Buyers Products Co. warrants all truck/trailer hardware manufactured or distributed by it, to be free from defects in material and workmanship for a period of one year from date of shipment. Parts must be properly installed and used under normal conditions. Any product which has been altered, including modification, misuse, accident or lack of maintenance will not be considered under warranty. Normal wear is excluded. The sole responsibility of Buyers Products Co. under this warranty is limited to repairing or replacing any part or parts which are returned, prepaid, and are found to be defective by Buyers Products Co. Authorization from Buyers Products Co. must be obtained before returning any part. No charges for transportation or labor performed on Buyers' products will be allowed under this warranty.