

----- USA only -----

**180** days warranty  
Tage Garantie

From the date of purchase +  
guaranteed spare part service

The warranty does not cover damages  
caused by improper use or neglect

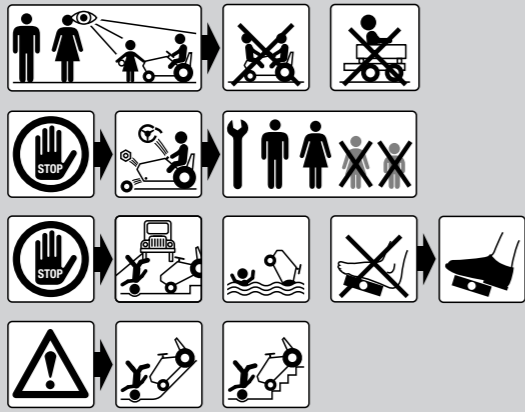

Ab Kaufdatum + garantierter Ersatzteilservice  
From the date of purchase + guaranteed spare part service  
A partir de la date d'achat + garantie service pièces détachées  
Dalla data di acquisto + garanzia parti di ricambio a partire

Ausgenommen gebrauchsbedingter Abnutzung  
The warranty does not cover damages  
caused by improper use or neglect  
La garantie est exclue en cas de défaut d'entretien  
ou d'utilisation anormale  
Sono esclusi danni causati da uso improprio o usura



36 Months - 72 Months



11/06

800.000.800.00



**Messhilfe für Verschraubungsmaterial**

Measuring help for screw connections • Gabarit pour système de serrage • Misura per il materiale di avvitamento

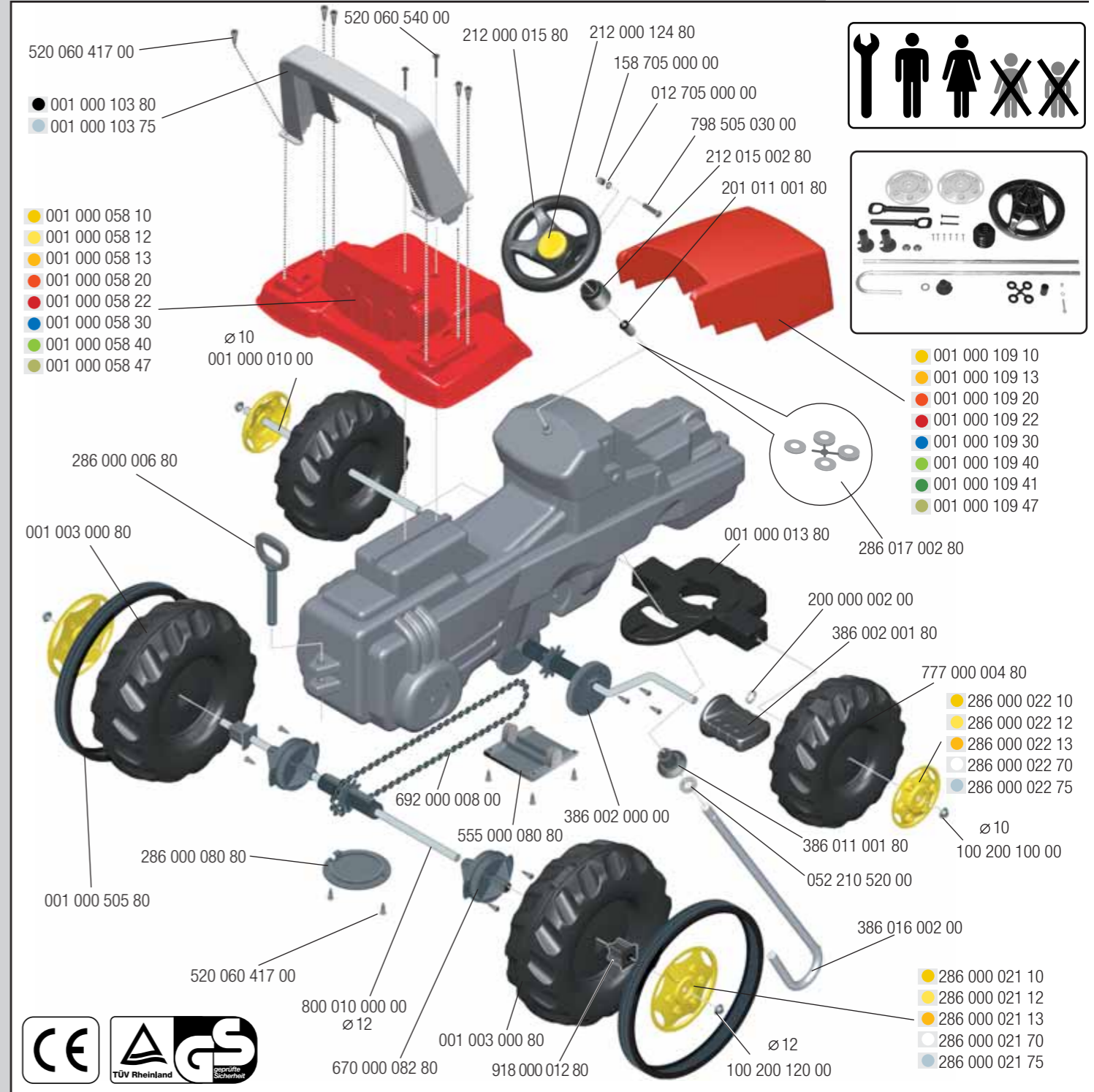
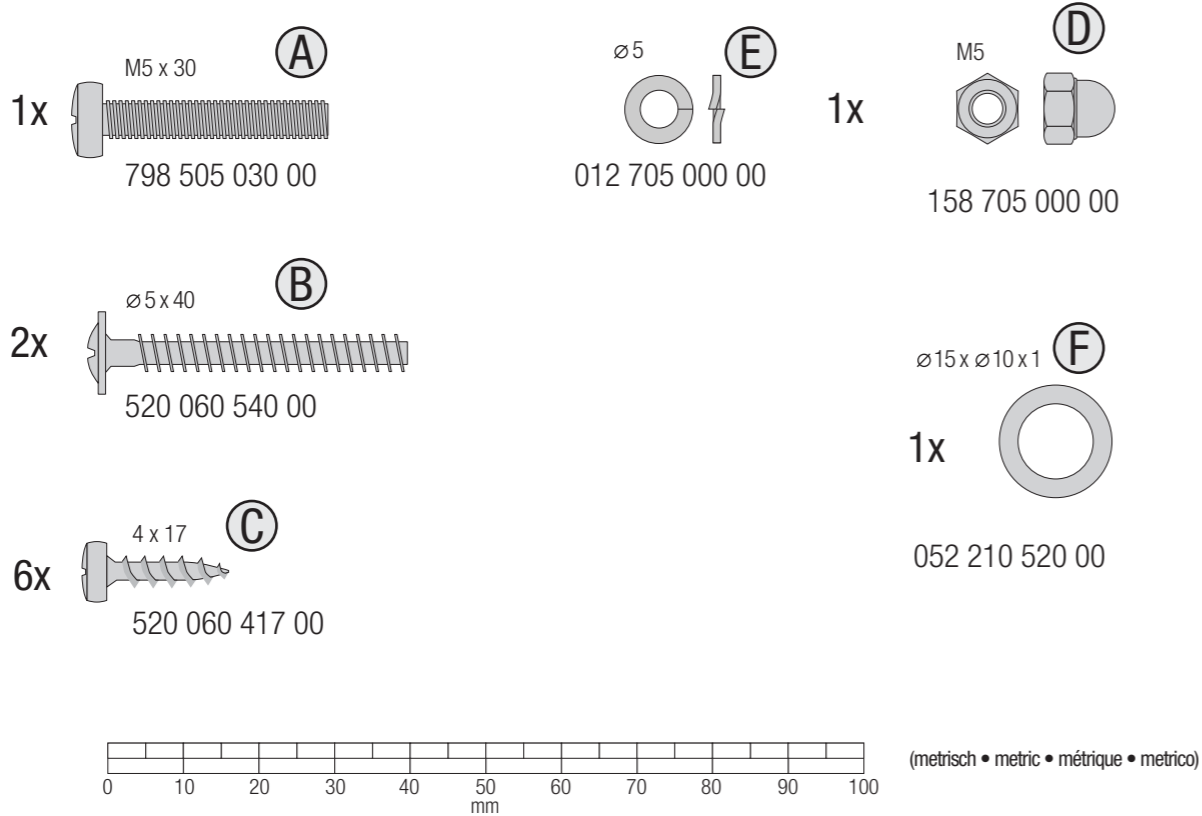

**WARNING**

- CHOKING HAZARD: Small parts. Danger of being swallowed.
- Contains small parts in non assembled state.
- Must be assembled by adults.
- Adult supervision required.
- Never use near steps, slopes, driveways, hills, roadways, alleys or swimming pool areas.
- Always wear shoes.
- Never allow more than one rider.
- The use of protective gear and a safety helmet is highly recommended.

Vertretungen • Representatives abroad • Agences • Rappresentanti all'estero

A Handelsagentur Kundgraber Tel. 0 22 30 / 79 0 79; Fax 0 22 30 / 79 0 80	HR domi Tel. 01240 84 20; Fax: 01240 96 96
AUS John Deere Ltd. Tel. 07 3802 / 3222; Fax 07 3803 / 6555	IRL Banaghan & Co. Ltd. Tel. 067 / 338 88; Fax 067 / 334 33
B/L Difrano P.V.B.A. Tel. 09 386 / 23 30; Fax 09 386 / 93 50	N ATEC AS (agricultural market) Tel. 051 77 07 30; Fax 051 77 07 40
CH Sombo AG Tel. 0 62 / 887 74 74; Fax 0 62 / 887 74 57	NL Born Agenturen Tel. 035 64 68 299; Fax 035 64 68 298
CY Costakis D. Koureas & Son LTD Tel. 025 71 13 08; Fax 025 71 13 32	PL Brimarex Tel. 061 / 862 07 00; Fax 061 / 867 93 23
CZ OLYMPtoY s.r.o. Tel. 0264 822 716; Fax 0264 822 341	RO RT CENTER SRL Tel. 0040 744 937 545; Fax 0040 269 212 099
DK/N Grandprix Aps, Bjarne Boie Tel. 049 17 / 60 78; Fax 049 17 / 60 70	RU 000 „JOHN-RUS“ Tel. 095 785 3993; Fax 095 369 6629
Service (DK/N/SE): Funnyland / Supertoys Tel. 075 61 / 10 70; Fax 075 61 / 10 95	SC Cobraplast d.o.o. Tel. +381 15 301240; Fax: +381 15 301242
FIN Hot-Toys OY Tel. 0 19-688 4765; Fax 0 19-688 4880	SE SpeedGame AB Tel. 042 23 86 85; Fax 042 23 86 95
F Claude Piveteau, Agence Commerciale Tel. 04 68 68 40 10; Fax 04 68 68 40 11	SLO Moko d.o.o. Tel. 01 729 51 20; Fax 01 729 51 27
GB Robbie Toys Ltd. Tel. 01 843 / 60 44 48; Fax 01 843 / 60 35 05	USA Kettler USA Tel. 001 757 427 24 00; Fax 001 757 427 01 83
GR John Hellas GmbH Tel. 023 10 68 86 54; Fax 023 10 68 89 10	ZA Jeffrey Stein Sales (PTY) Ltd. ZA-8001 Cape Town
GY Farfan and Mendes Limited Tel. 592 226 8130; Fax: 592 225 8651	



Achtung, verschluckbare Teile!  
Contains small parts,  
danger of being swallowed!  
Contient des petites pièces détachables  
pouvent être avalées!

**rolly toys Service:**  
Tel: +49 (0) 95 68 / 85 61 46  
Fax: +49 (0) 95 68 / 85 61 83  
e-mail: service@rollytoys.de

**Franz Schneider GmbH & Co KG**  
P.O.Box 1460  
D-96 459 · Neustadt bei Coburg · Germany  
Tel.: +49 (0) 95 68 / 8 56-0  
Fax.: +49 (0)95 68 / 8 56-190  
www.rollytoys.com · e-mail: service@rollytoys.de

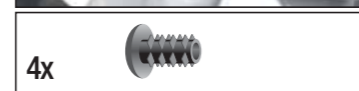
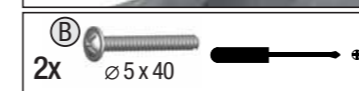
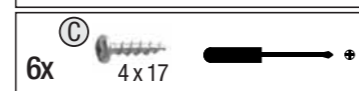
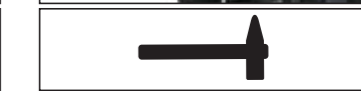
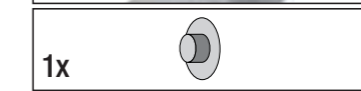
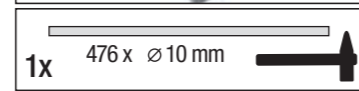
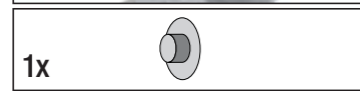
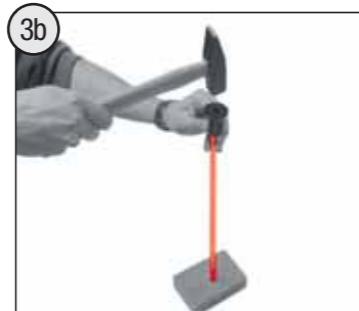
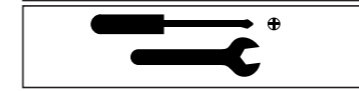
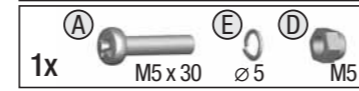
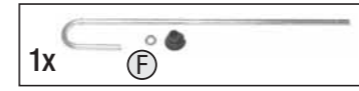
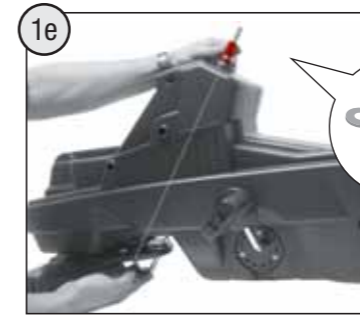
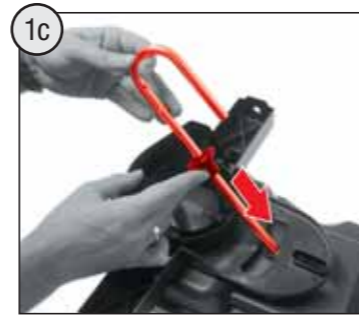
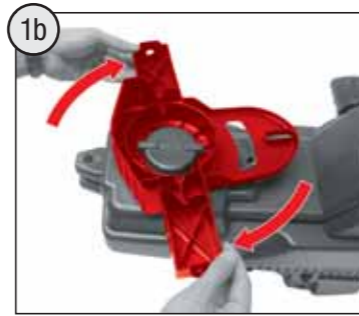



## Messhilfe für Verschraubungsmaterial

Measuring help for screw connections • Gabarit pour système de serrage • Misura per il materiale di avvitamento

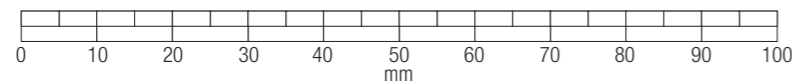
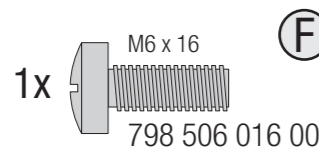
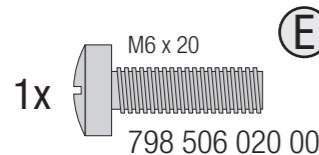
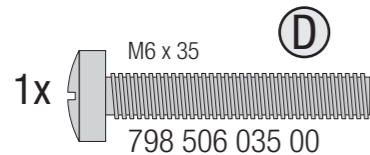
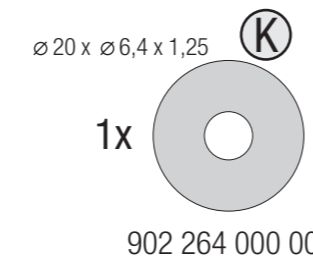
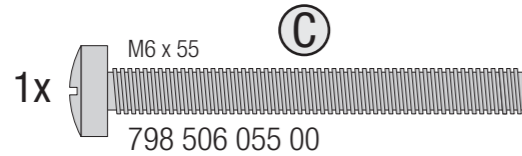
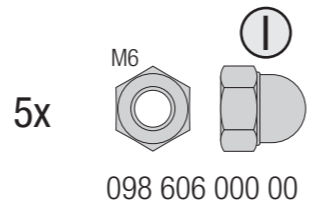
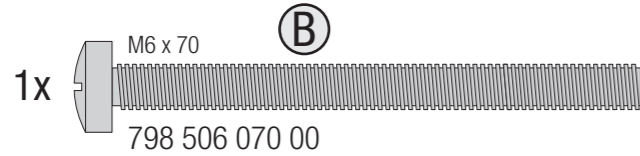
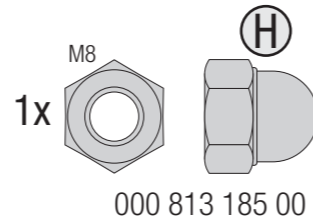
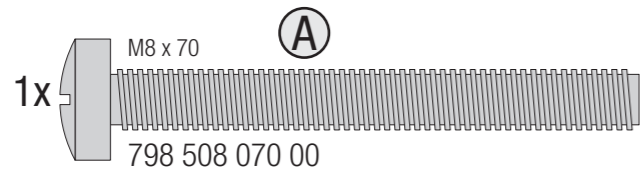

(metrisch • metric • métrique • metrico)

## WARNING

- **CHOKING HAZARD:** Small parts. Danger of being swallowed. Contains small parts in non assembled state. Must be assembled by adults.
- Adult supervision required.
- Never use near steps, slopes, driveways, hills, roadways, alleys or swimming pool areas.
- Always wear shoes.
- Never allow more than one rider.
- The use of protective gear and a safety helmet is highly recommended.

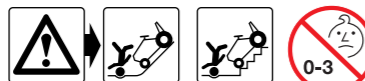
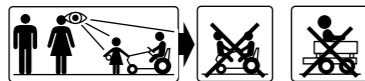

### Ab Kaufdatum + garantierter Ersatzteilservice

From the date of purchase + guaranteed spare part service  
A partir de la date d'achat + garantie service pièces détachées  
Dalla data di acquisto + garanzia parti di ricambio a partire

### Ausgenommen gebrauchsbedingter Abnutzung

The warranty does not cover damages caused by improper use or neglect  
La garantie est exclue en cas de défaut d'entretien ou d'utilisation anormale  
Sono esclusi danni causati da uso improprio o usura

### ----- USA only -----

**180**  
days warranty  
Tage Garantie

### From the date of purchase + guaranteed spare part service

Ab Kaufdatum + garantierter Ersatzteilservice  
A partir de la date d'achat + garantie service pièces détachées  
Dalla data di acquisto + garanzia parti di ricambio a partire

### The warranty does not cover damages caused by improper use or neglect

Ausgenommen gebrauchsbedingter Abnutzung  
La garantie est exclue en cas de défaut d'entretien ou d'utilisation anormale  
Sono esclusi danni causati da uso improprio o usura

# Heckbagger

excavator • pelleteuse arrière • escavatore posteriore

36 Months - 9 Years

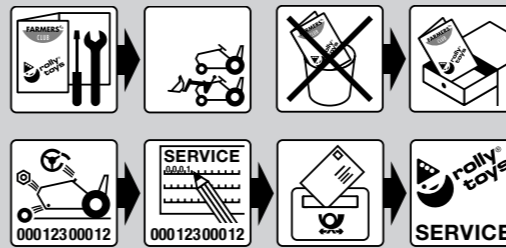

**rolly toys Service:**

Tel: +49 (0) 95 68 / 85 61 46

Fax: +49 (0) 95 68 / 85 61 83

e-mail: service@rollytoys.de

12 / 05

932.000.800.00

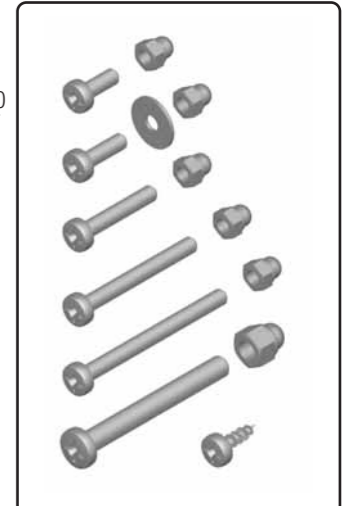
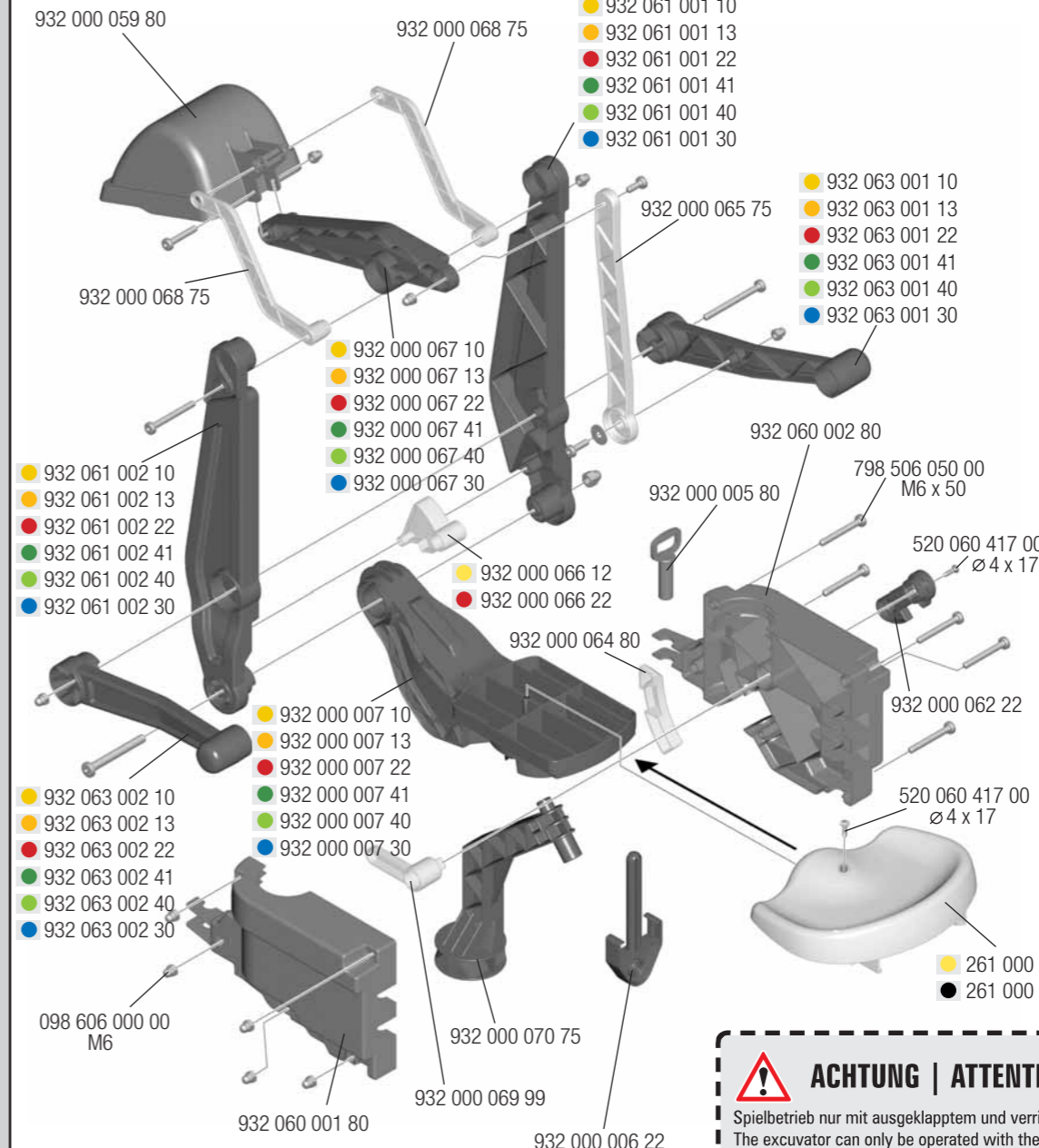

**ACHTUNG | ATTENTION | ATTENZIONE**

Spielbetrieb nur mit ausgeklapptem und verriegeltem Stützbein vornehmen.  
The excavator can only be operated with the folding and locking support leg in position.  
Avant d'utiliser ce modèle, prendre bien soin de déployer et de verrouiller la béquille.  
Durante il gioco il piede deve essere assolutamente appoggiato a terra e bloccato.

Vertretungen • Representatives abroad • Agences • Rappresentanti all'estero		
<b>A</b> Handelsagentur Kundebraber Tel. 0 22 30 / 79 0 79; Fax 0 22 30 / 79 0 80	<b>F</b> Claude Piveteau, Agence Commerciale Tel. 04 68 68 40 10; Fax 04 68 68 40 11	<b>RO</b> RT CENTER SRL Tel. 0040 744 937 545; Fax 0040 269 212 099
<b>AUS</b> John Deere Ltd. Tel. 07 3802 / 3222; Fax 07 3803 / 6555	<b>GB</b> Robbie Toys Ltd. Tel. 01 843 / 60 44 48; Fax 01 843 / 60 35 05	<b>RU</b> 000 „JOHN-RUS“ Tel. 095 785 3993; Fax 095 369 6629
<b>B/L</b> Diframo P.V.B.A. Tel. 09 386 / 23 30; Fax 09 386 / 93 50	<b>GR</b> John Hellas GmbH Tel. 023 10 68 86 54; Fax 023 10 68 89 10	<b>SC</b> Cobraplast d.o.o. Tel. +381 15 301240; Fax: +381 15 301242
<b>CH</b> Sombo AG Tel. 0 62 / 887 74 74; Fax 0 62 / 887 74 57	<b>GY</b> Farfan and Mendes Limited Tel. 592 226 8130; Fax: 592 225 8651	<b>SE</b> SpeedGame AB Tel. 042 23 86 85; Fax 042 23 86 95
<b>CY</b> Costakis D. Koureas & Son LTD Tel. 025 71 13 08; Fax 025 71 13 32	<b>HR</b> domi Tel. 01240 84 20; Fax: 01240 96 96	<b>SLO</b> Moko d.o.o. Tel. 01 729 51 20; Fax: 01 729 51 27
<b>CZ</b> OLYMPtoys s.r.o. Tel. 0284 822 716; Fax 0284 822 341	<b>IRL</b> Banaghan & Co. Ltd. Tel. 067 / 338 88; Fax 067 / 334 33	<b>USA</b> Kettler USA; Greg Keeton Tel. 001 757 427 24 00; Fax 001 757 427 01 83
<b>DK</b> Grandprix Aps, Bjarne Boie Tel. 049 17 / 60 78; Fax 049 17 / 60 70	<b>N</b> ATEC AS (agricultural market) Tel. 051 77 07 30; Fax 051 77 07 40	<b>ZA</b> Jeffrey Stein Sales (PTY) Ltd. ZA-8001 Cape Town
<b>Service: Funnyland / Supertoys</b> Tel. 075 61 / 10 70; Fax 075 61 / 10 95	<b>NL</b> Born Agenturen Tel. 035 64 68 299; Fax 035 64 68 298	
<b>FIN</b> Hot-Toys OY Tel. 0 19-688 4765; Fax 0 19-688 4880	<b>PL</b> Brimarex Tel. 061 / 862 07 00; Fax 061 / 867 93 23	



**Franz Schneider GmbH & Co KG**  
P.O.Box 1460  
D-96 459 · Neustadt bei Coburg · Germany  
Tel.: +49 (0) 95 68 / 8 56-0  
Fax.: +49 (0)95 68 / 8 56-190  
www.rollytoys.com · e-mail: service@rollytoys.de



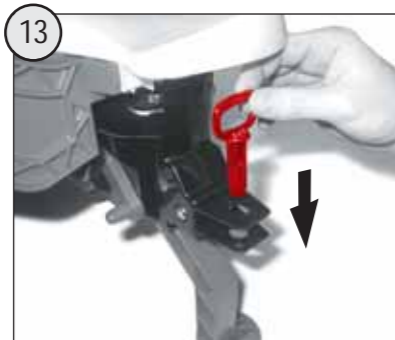
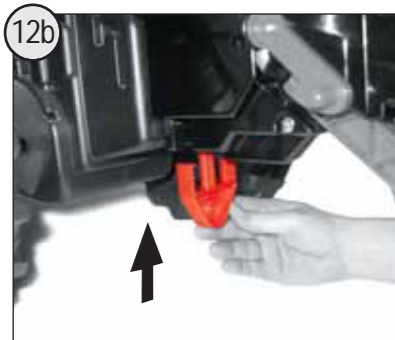
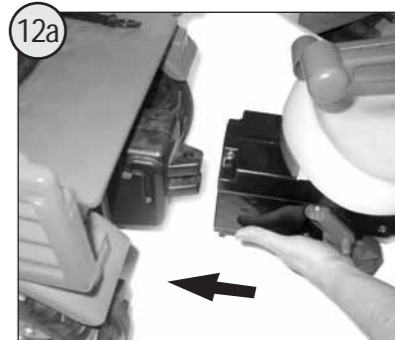
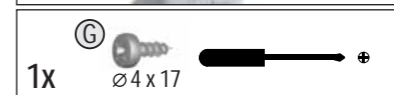
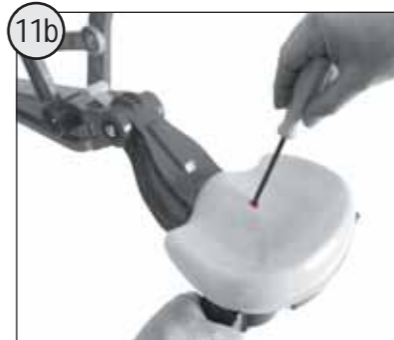
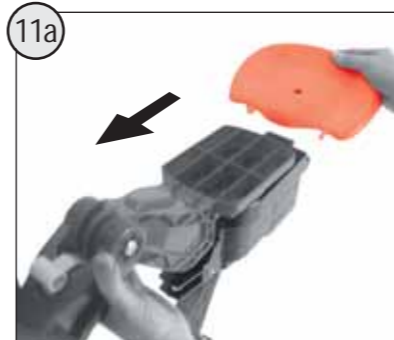
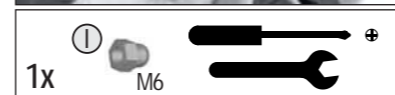
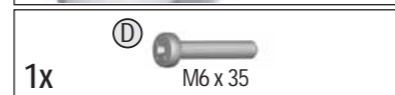
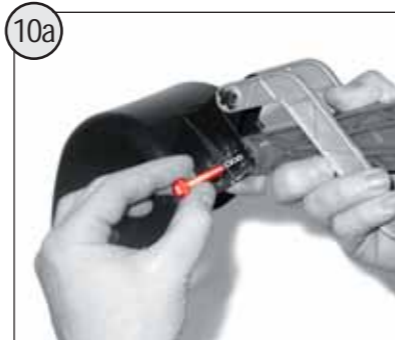
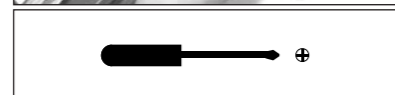
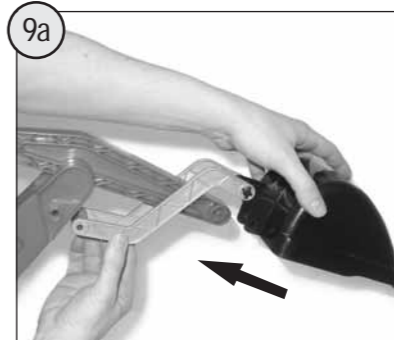
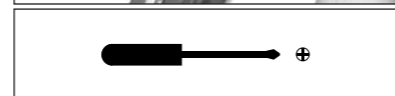
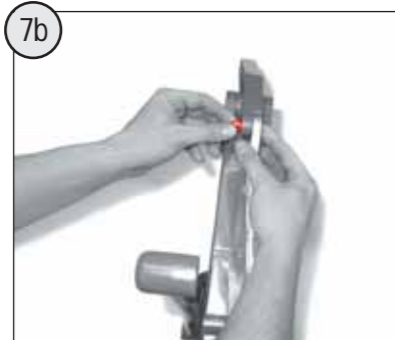
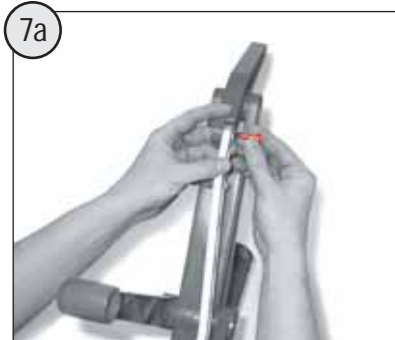
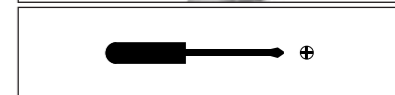
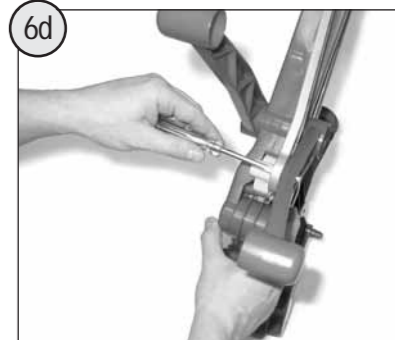
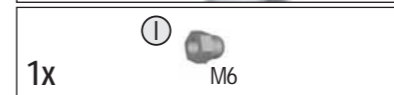
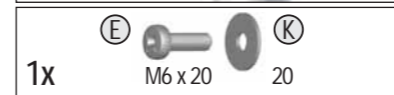
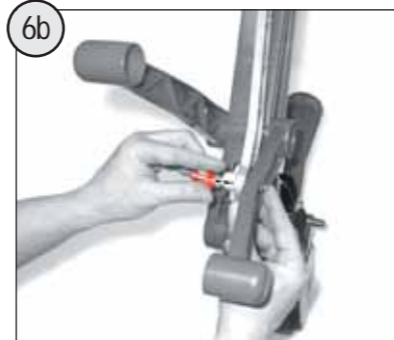
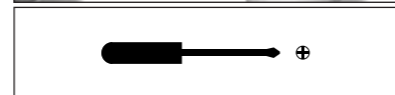
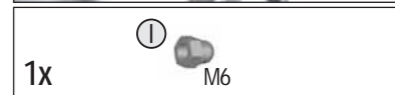
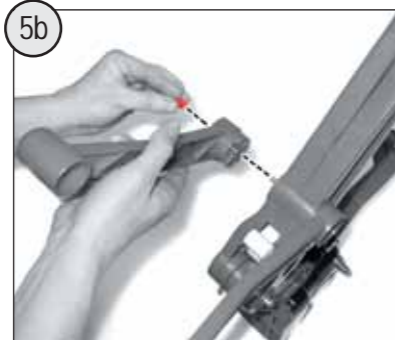
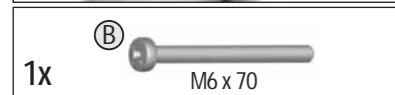
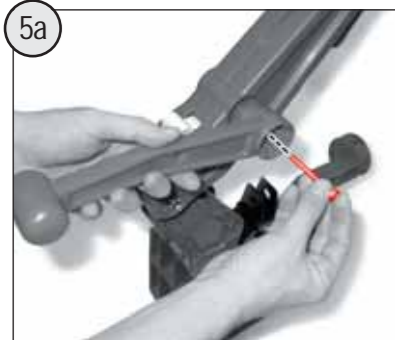
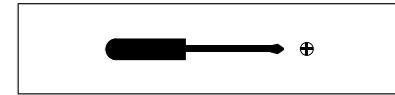
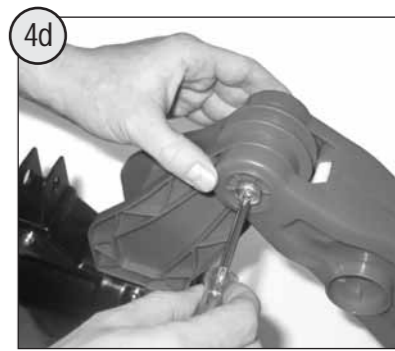
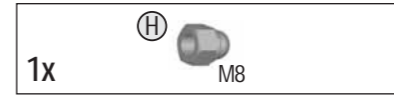
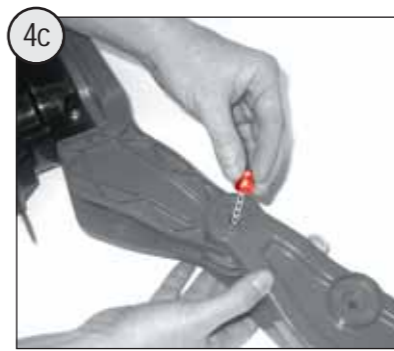
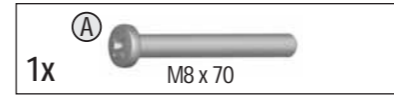
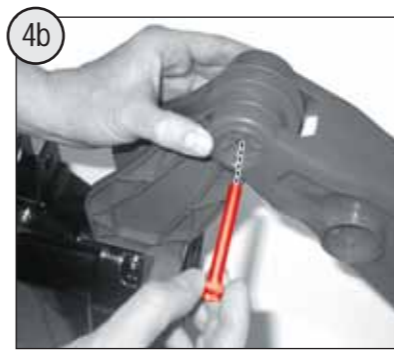
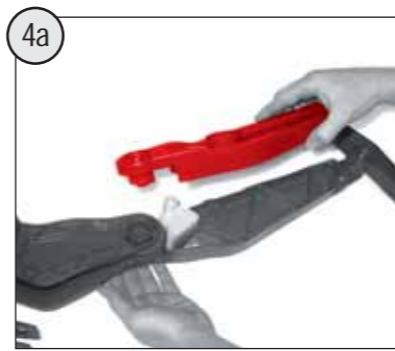
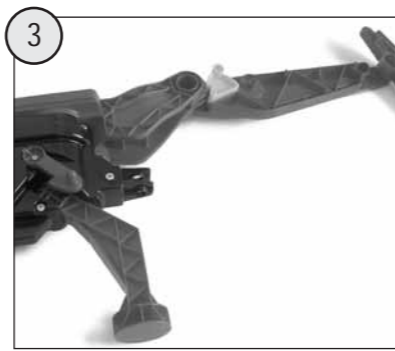
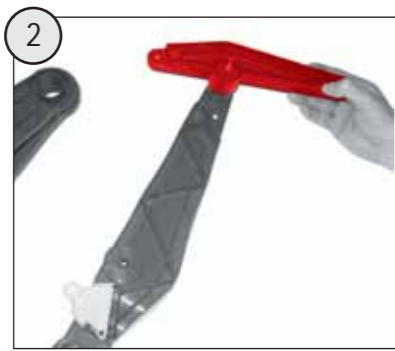
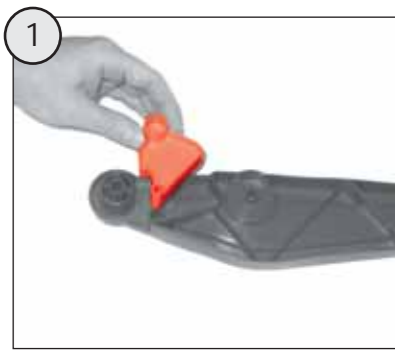



- Achtung! Zum Verriegeln des Stützfußes und des Auslegers in Ruheposition genau in dieser Reihenfolge vorgehen!
- Caution! Proceed as follows to lock the support and set the arm of the excavator in stand-by position.
- Attention! Procéder de la manière suivante pour verrouiller le pied d'appui et mettre le bras de l'excavateur en position de rangement:
- Attenzione! Per sbloccare la sicurezza girare il braccio escavatore di 90° (posizione di riposo) e poi alzare il piede.

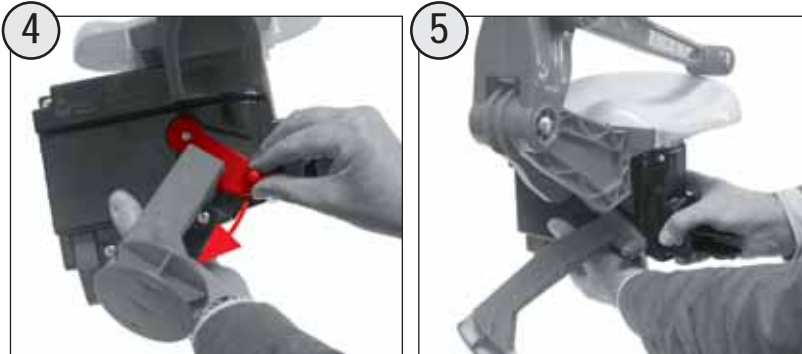
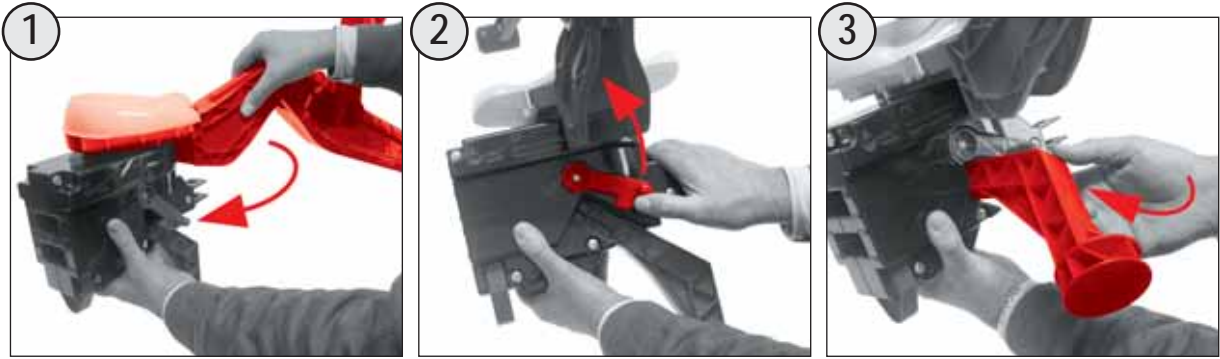

### To Lift the Support Peg for Riding

- 1 Rotate Back Hoe Seat all the way to the left until the Seat stops.
- 2 Lift the Release Lever up to allow the Support Peg to be raised off the ground.
- 3 Raise the Support Peg all the way up.
- 4 Lower the Release Lever to lock the Support Peg into the raised position for safe riding.



- Achtung! Zum Ausschwenken des Stützfußes und Entriegeln des Auslegers in Arbeitsposition genau in dieser Reihenfolge vorgehen!
- Caution! Proceed as follows to unlock the support and open the arm of the excavator in working position.
- Attention! Procéder de la manière suivante pour déverrouiller le pied d'appui et déployer le bras de l'excavateur en position de service:
- Attenzione! Per tornare nella posizione di lavoro abbassare il piede di sostegno e rigirare di 90° il braccio.

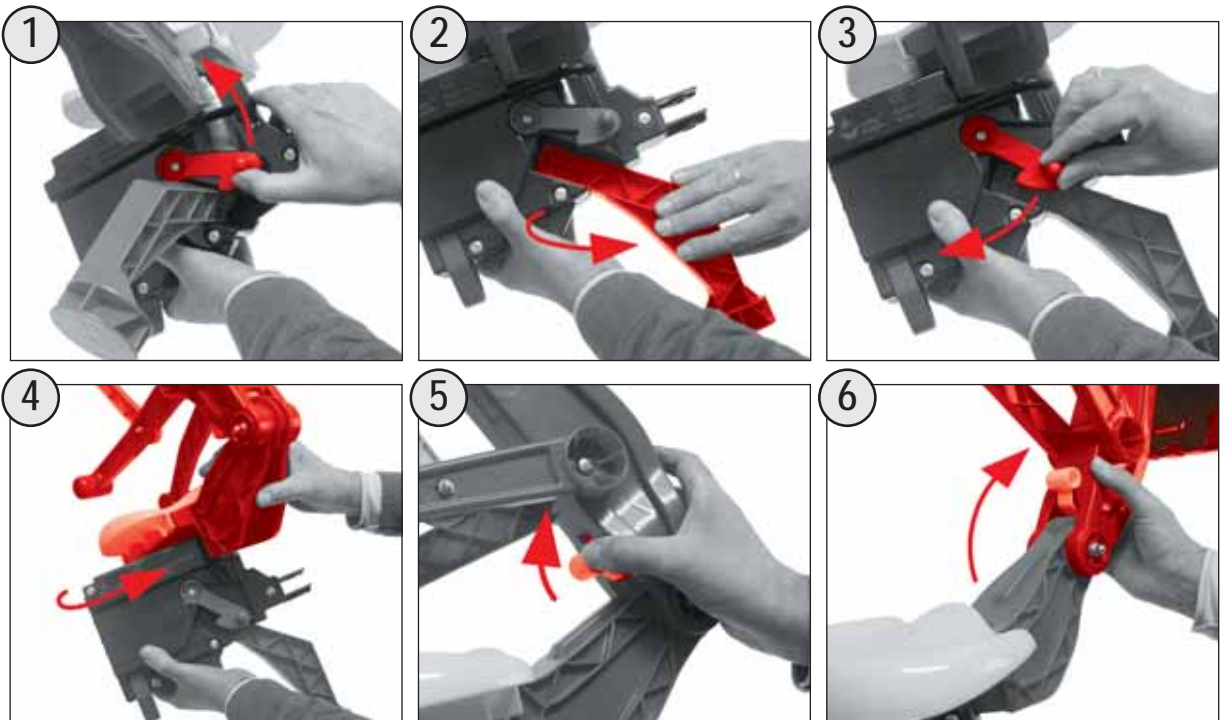

### To Lower the Back Hoe Support Peg for Play

- 1 Raise the Lever to release the Support Peg.
- 2 Lower the Support Peg until it touches the ground.
- 3 Lower the Lever to lock the Support Peg into place.
- 4 Rotate the Back Hoe into the play position.
- 5 To release the Back Hoe arm, lift the Red Release Lever.
- 6 Lower the Back Hoe Arm. The release will auto lock when raised.





# rolly® junior lader

36 Months - 72 Months



rolly toys Kundendienst Deutschland:

Tel: +49 (0) 95 68 / 856-142

Fax: +49 (0) 95 68 / 856-183

e-mail: service@rollytoys.de



2009/10

933.000.800.00

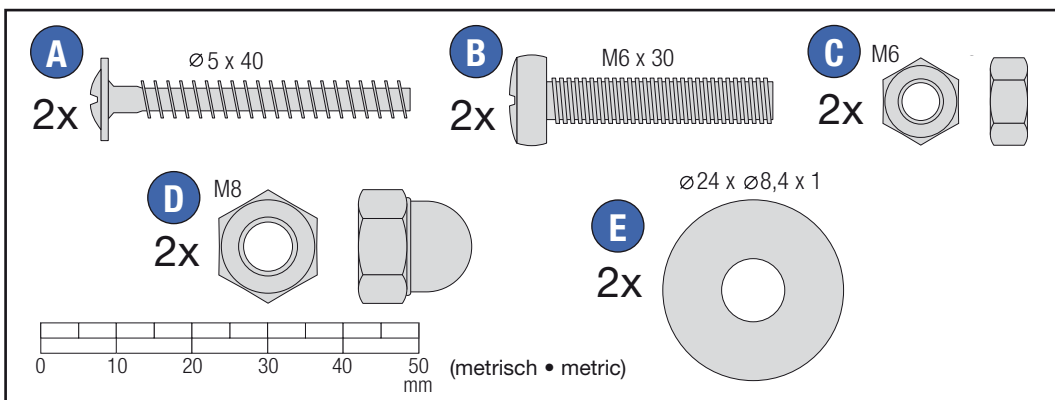
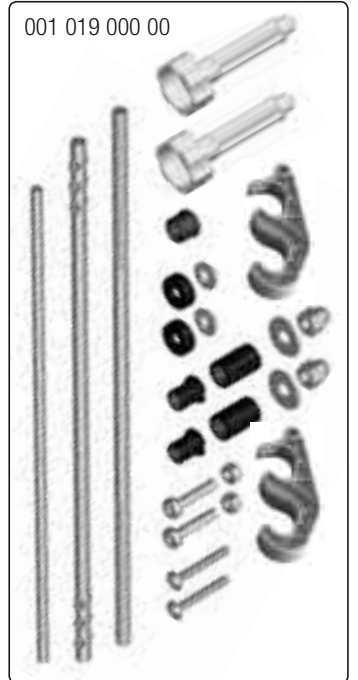
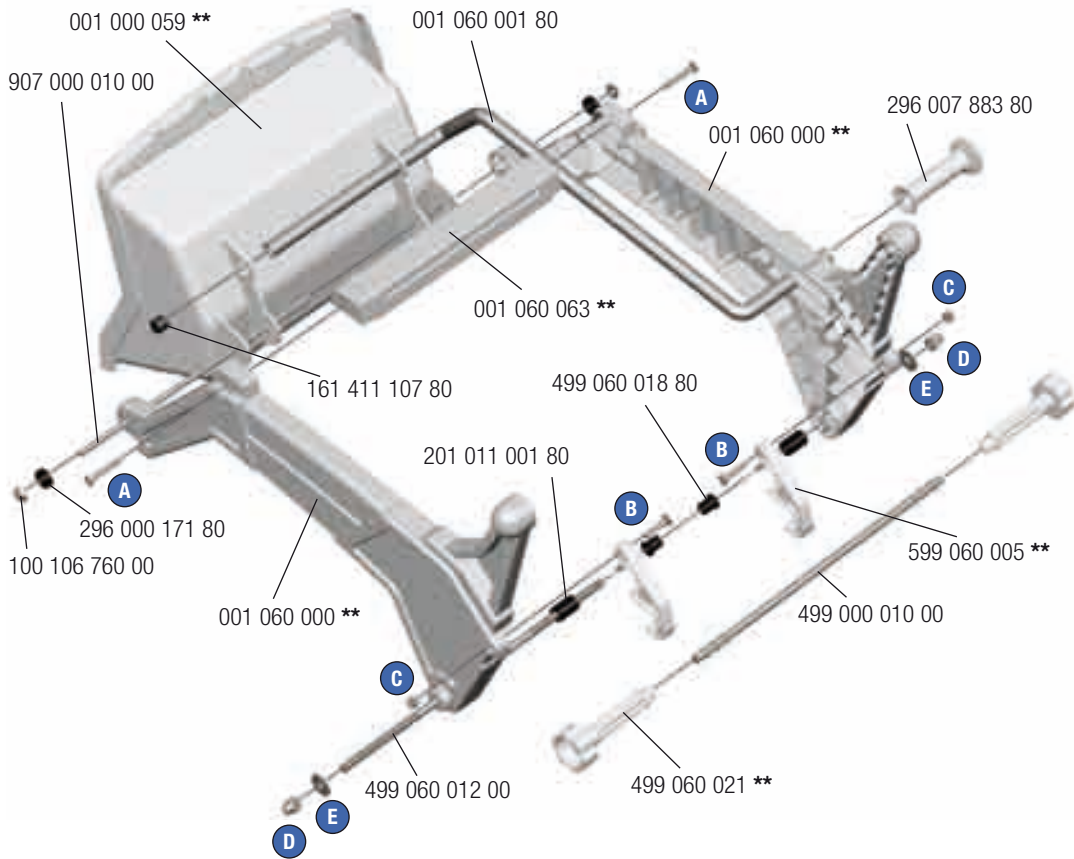

→ **		
● +10	● +26	● +47
● +12	● +30	● +51
● +13	● +37	● +54
● +20	● +40	● +70
● +22	● +41	● +75
● +23	● +44	● +80



made in Germany

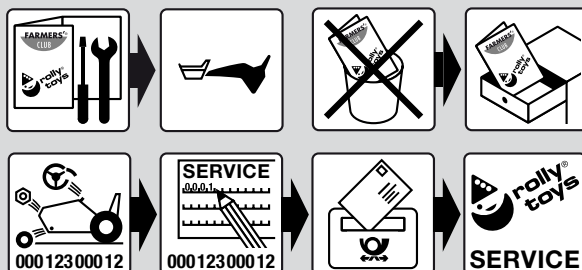

Franz Schneider GmbH & Co KG

P.O.Box 1460

D-96459 · Neustadt bei Coburg · Germany

Tel.: +49 (0) 95 68 / 856-0

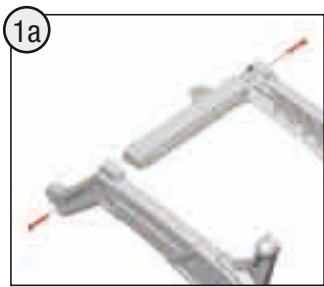

Fax.: +49 (0) 95 68 / 856-190

www.rollytoys.com

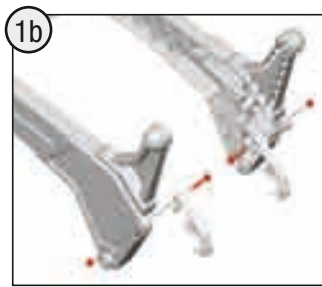

2x   $\varnothing 5 \times 40$



2x   $M6 \times 30$   M6

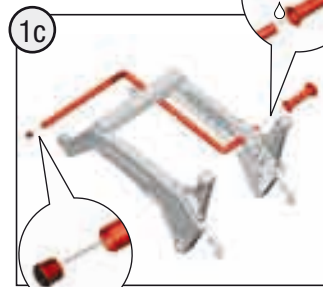

1x 

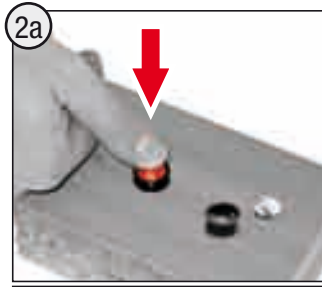
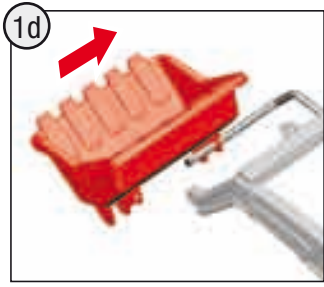

2x  

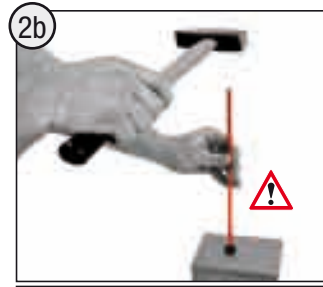

1x  $\varnothing 6 \times 306\text{mm}$

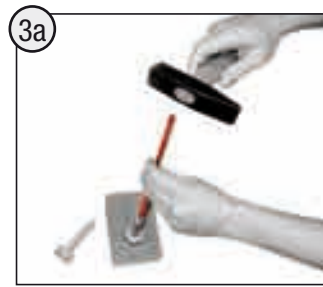
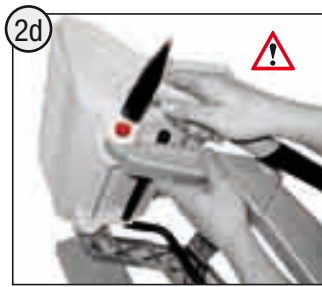
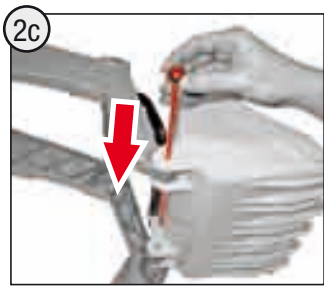

1x  $\varnothing 8 \times 335\text{mm}$

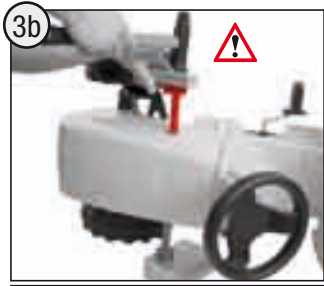

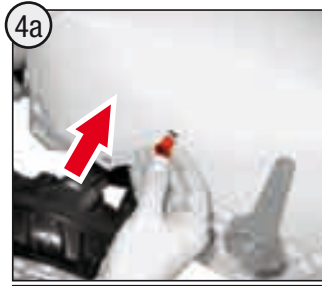

1x 

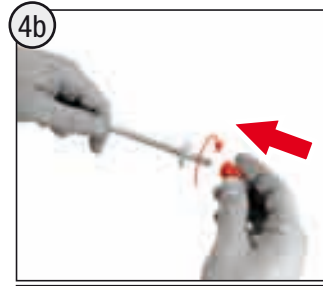

2x  $\varnothing 12 \times 16\text{mm}$



1x  $\varnothing 8 \times 345\text{mm}$   

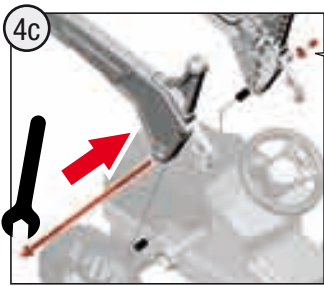

1x  $\varnothing 8,4 \times \varnothing 24 \text{ M8}$   

--- NORTH & SOUTH AMERICA only ---

**180 days** warranty

From the date of purchase + guaranteed spare part service

The warranty does not cover damages caused by improper use or neglect



Achtung! Erstickungsgefahr!  
Danger of suffocation!

## WARNING

- CHOKING HAZARD: Small parts. Danger of being swallowed. Contains small parts in non assembled state. Must be assembled by adults.
- Adult supervision required.
- Never use near steps, slopes, driveways, hills, roadways, alleys or swimming pool areas.
- Always wear shoes.
- Never allow more than one rider.
- The use of protective gear and a safety helmet is highly recommended.
- Conforms to the requirements of ASTM Standard Consumer Safety Specification on Toy Safety, F 963